

GENERAL NOTES :

CONVEYOR WEIGHT : 1011 LB (without garment)
 APPROX. STORAGE CAPACITY : 1236 GARMENTS

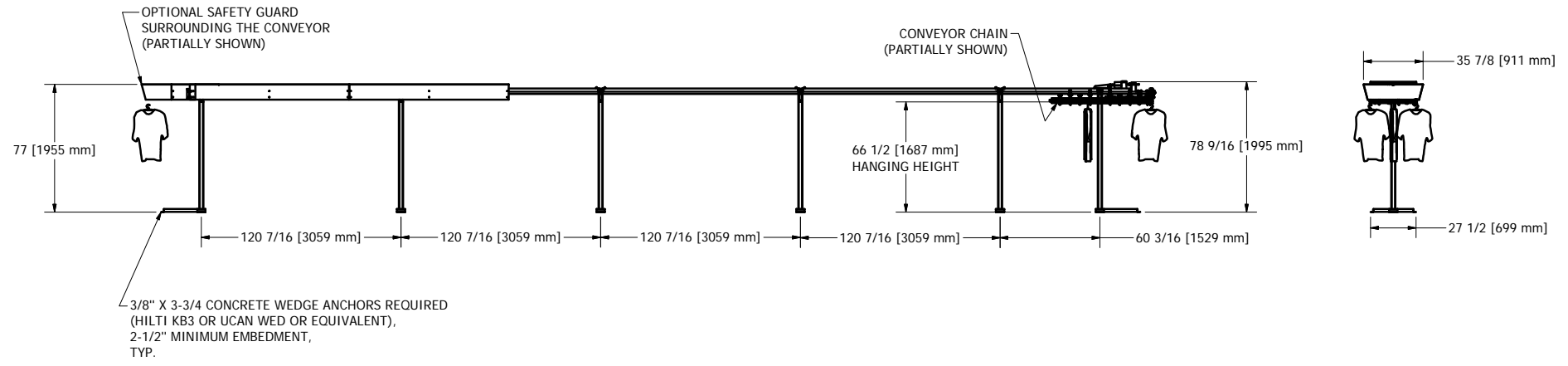
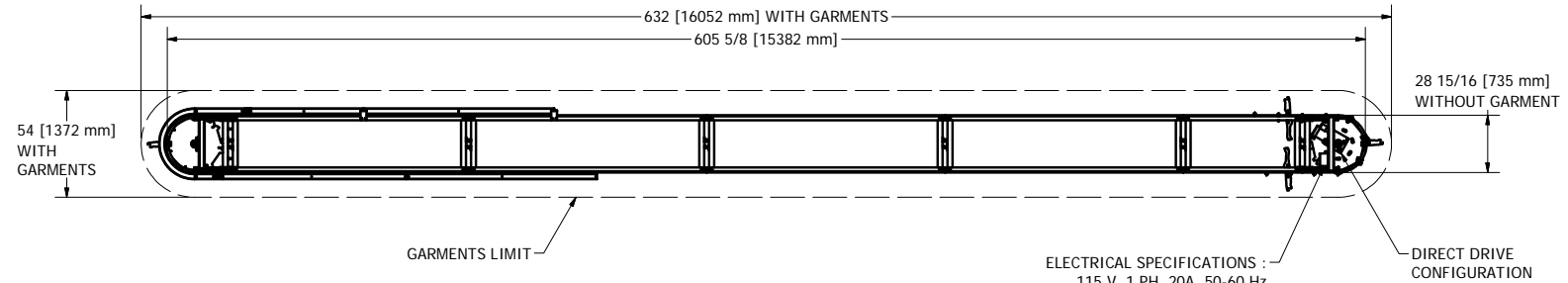
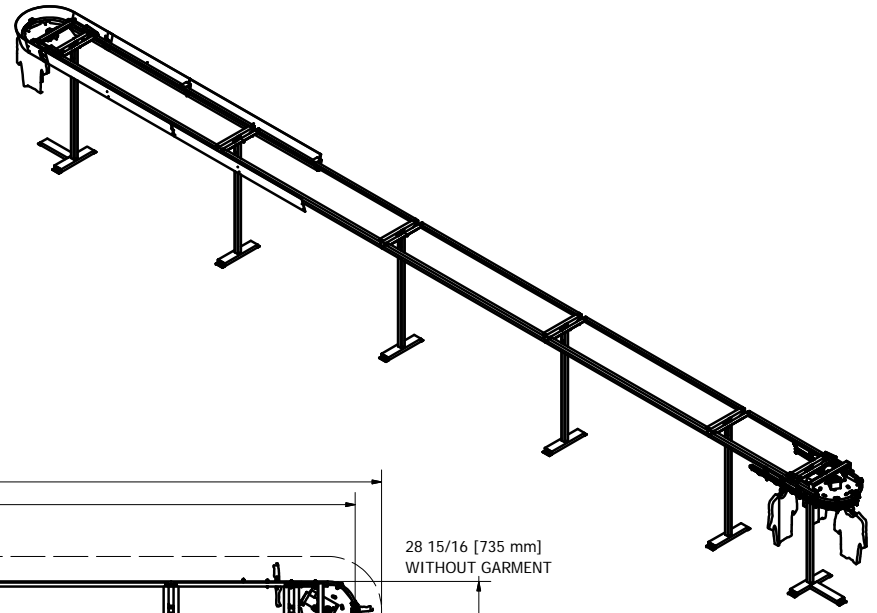

DESIGN F. ROULEAU	DATE 2/3/2010	 www.planiform.com
DRAWN S. ROUS.-L.	DATE 2/3/2010	
CHECKED	DATE	
GENERAL TOLERANCES .X +/- .030 .XX +/- .010 .XXX +/- .005 FRACTION +/- 1/16		TITLE GARMENT CONVEYOR SIZE DWG NO C NPF-1030 SCALE 1/4" = 1'-0"
		REV