

GENERAL NOTES :

CONVEYOR WEIGHT : 383 LB (without garment)
 APPROX. STORAGE CAPACITY : 552 GARMENTS
BRACING REQUIRED

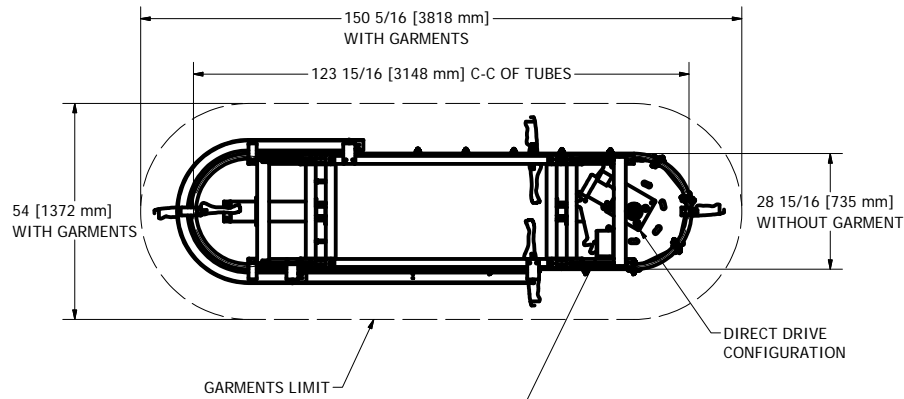

ELECTRICAL SPECIFICATIONS :
 115 V, 1 PH, 20A, 50-60 Hz

OPTIONAL SAFETY GUARD
 SURROUNDING THE CONVEYOR
 (PARTIALLY SHOWN)

CONVEYOR CHAIN
 (PARTIALLY SHOWN)

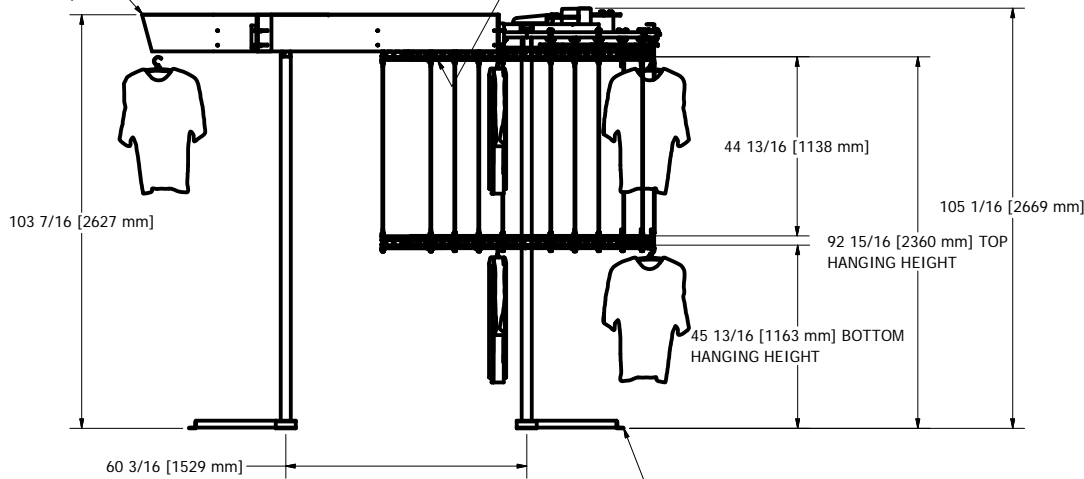

3/8" X 3-3/4 CONCRETE WEDGE ANCHORS REQUIRED
 (HILTI KB3 OR UCAN WED OR EQUIVALENT),
 2-1/2" MINIMUM EMBEDMENT,
 TYP.

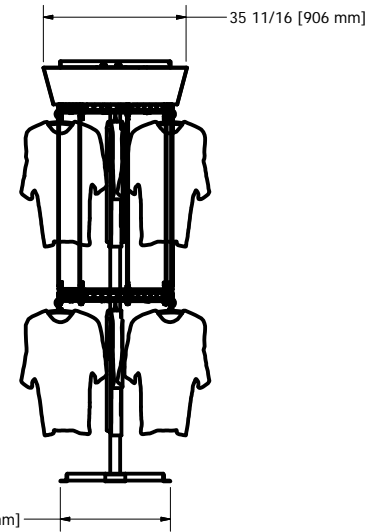
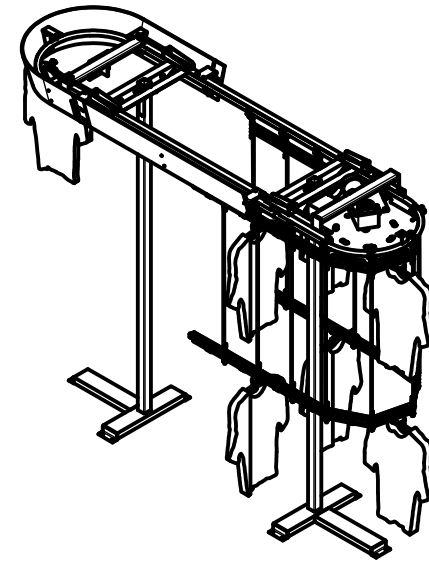

DESIGN F. ROULEAU	DATE 8/21/2008
DRAWN S. ROUS.-L.	DATE 1/15/2010
CHECKED	DATE
GENERAL TOLERANCES	
.X	+/- .030
.XX	+/- .010
.XXX	+/- .005
FRACTION	+/- 1/16

www.planiform.com		Planiform Conveyors	
TITLE GARMENT CONVEYOR			
SIZE C	DWG NO NPF-230-DD	SCALE 1/2" = 1'-0"	REV