

GENERAL NOTES :

CONVEYOR WEIGHT : 330 LB (without garment)

APPROX. STORAGE CAPACITY : 276 GARMENTS

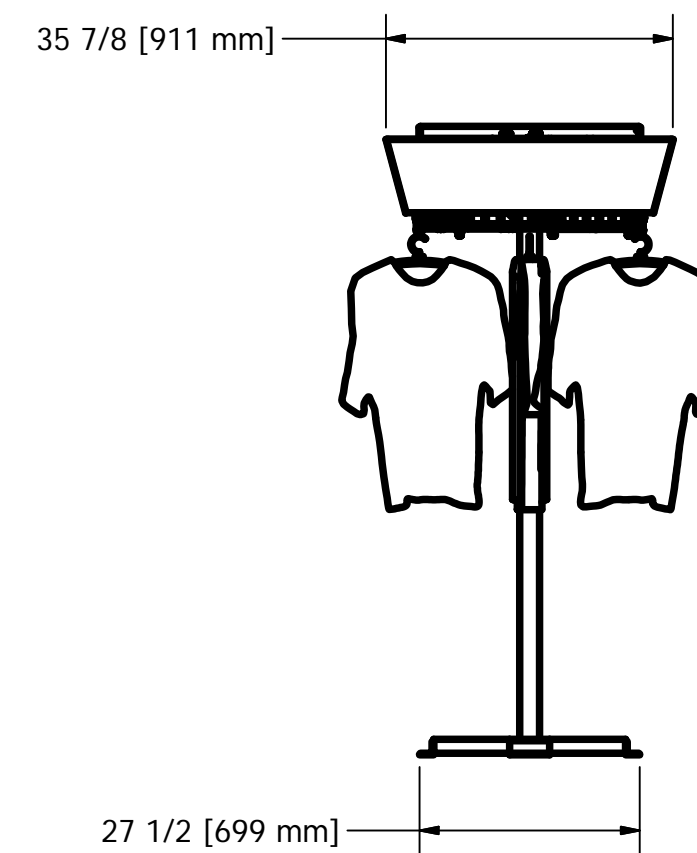
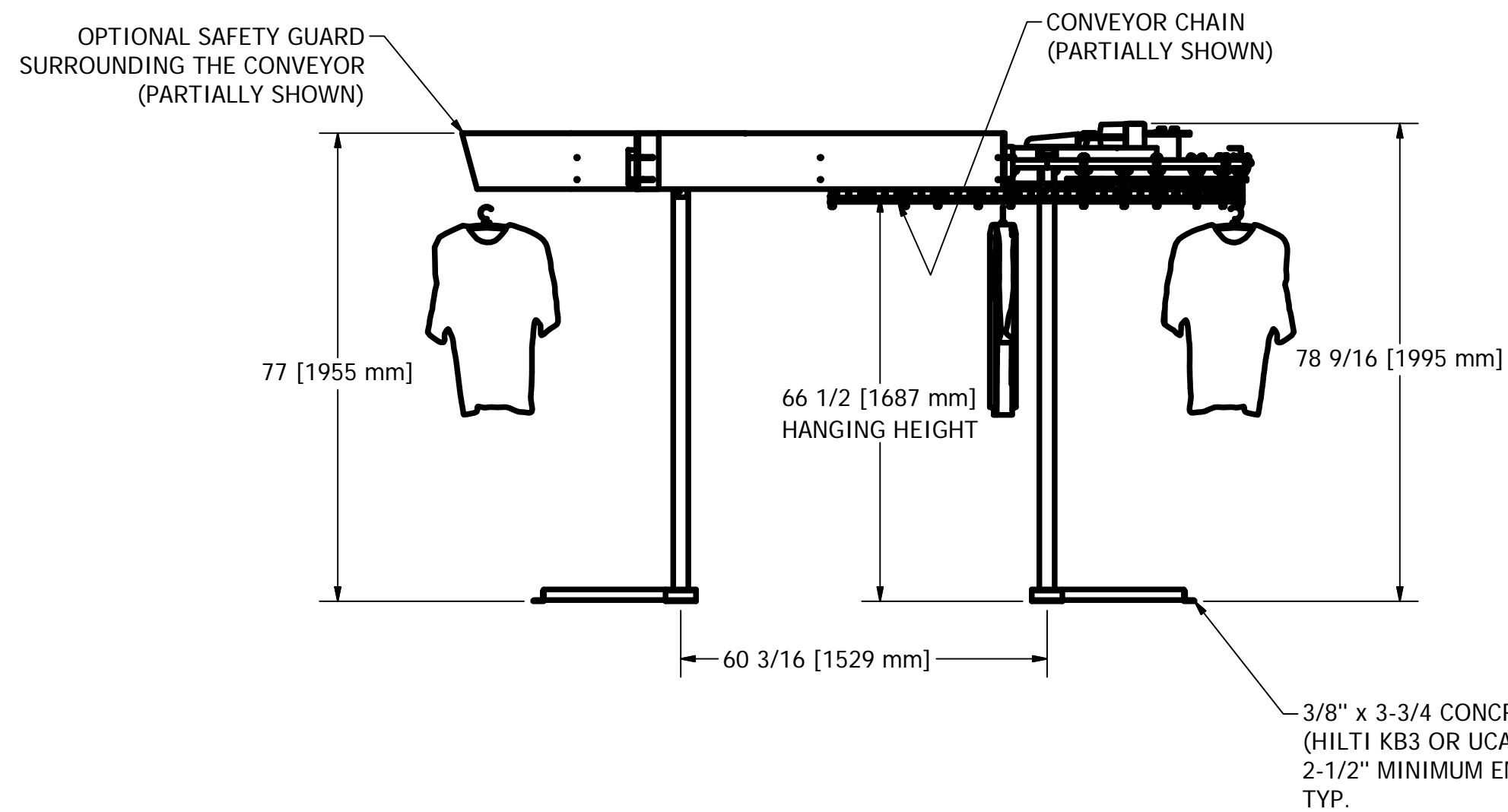
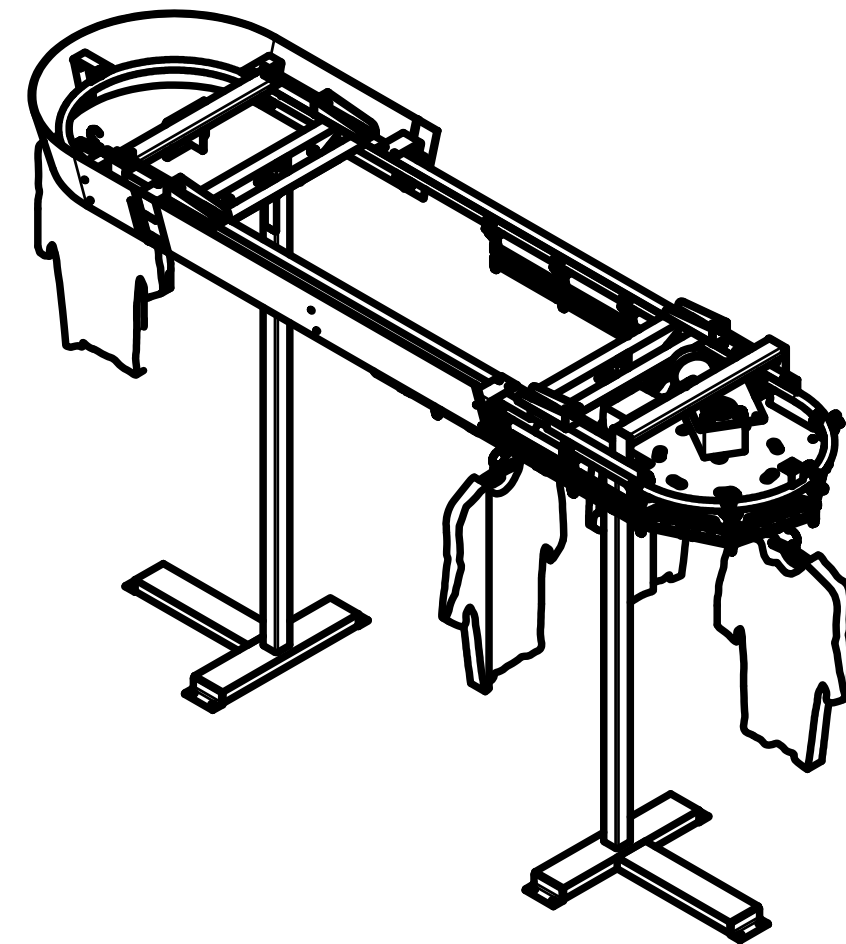
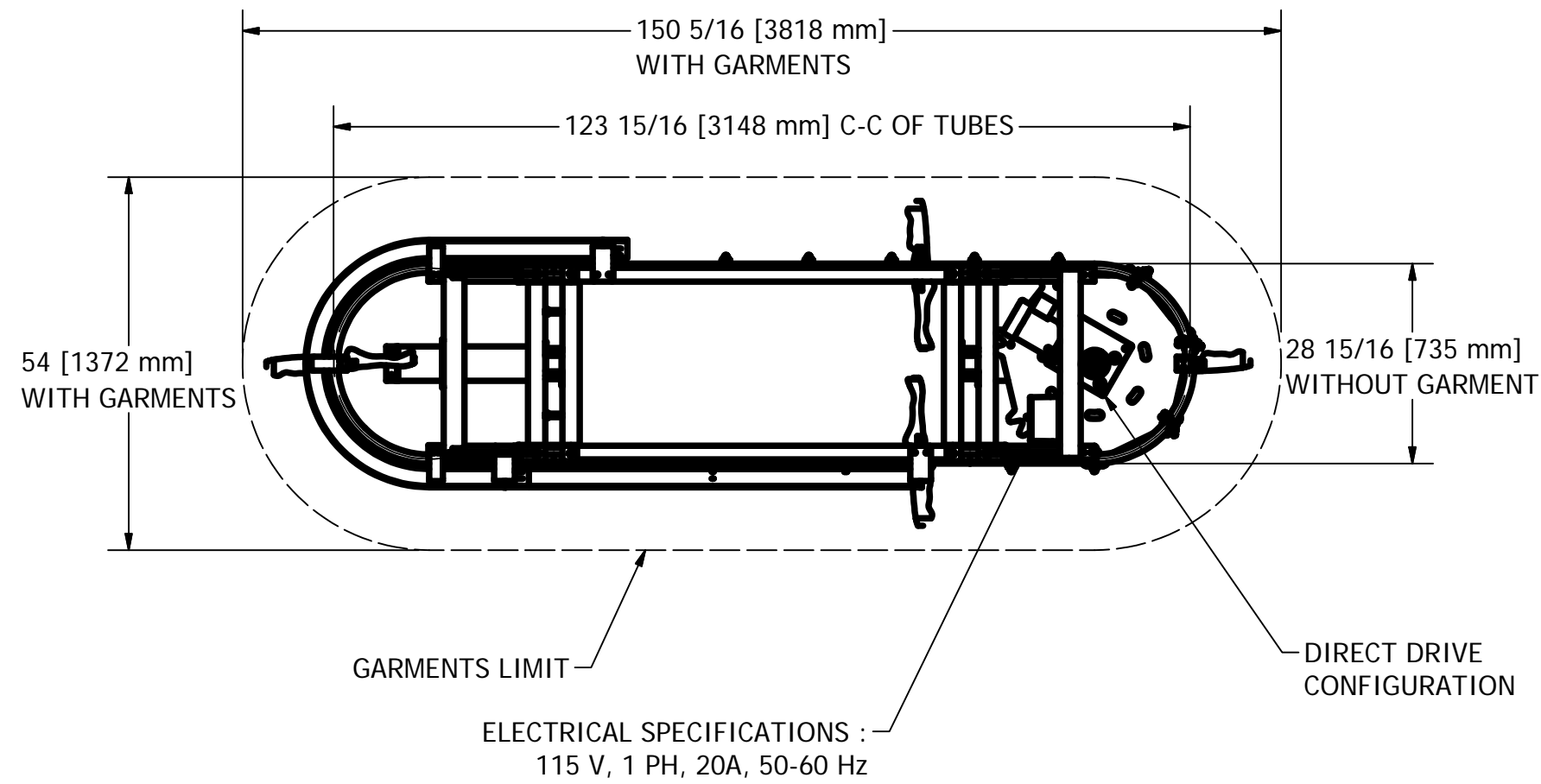

DESIGN	DATE
F. ROULEAU	8/21/2008
DRAWN	DATE
S. ROUS.-L.	1/12/2010
CHECKED	DATE
GENERAL TOLERANCES	
.X	+/- .030
.XX	+/- .010
.XXX	+/- .005
FRACTION	+/- 1/16

		TITLE	
		GARMENT CONVEYOR	
SIZE	DWG NO	SCALE	REV
C	NPF-230	1/2" = 1'-0"	