

**GENERAL NOTES :**

CONVEYOR WEIGHT : 354 LB (without garment)  
 APPROX. STORAGE CAPACITY : 324 GARMENTS

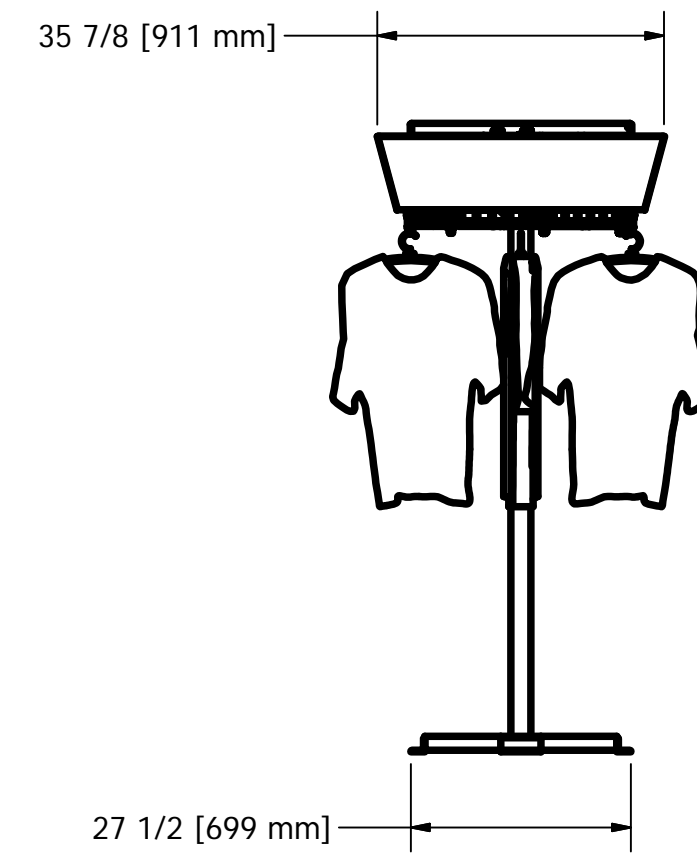
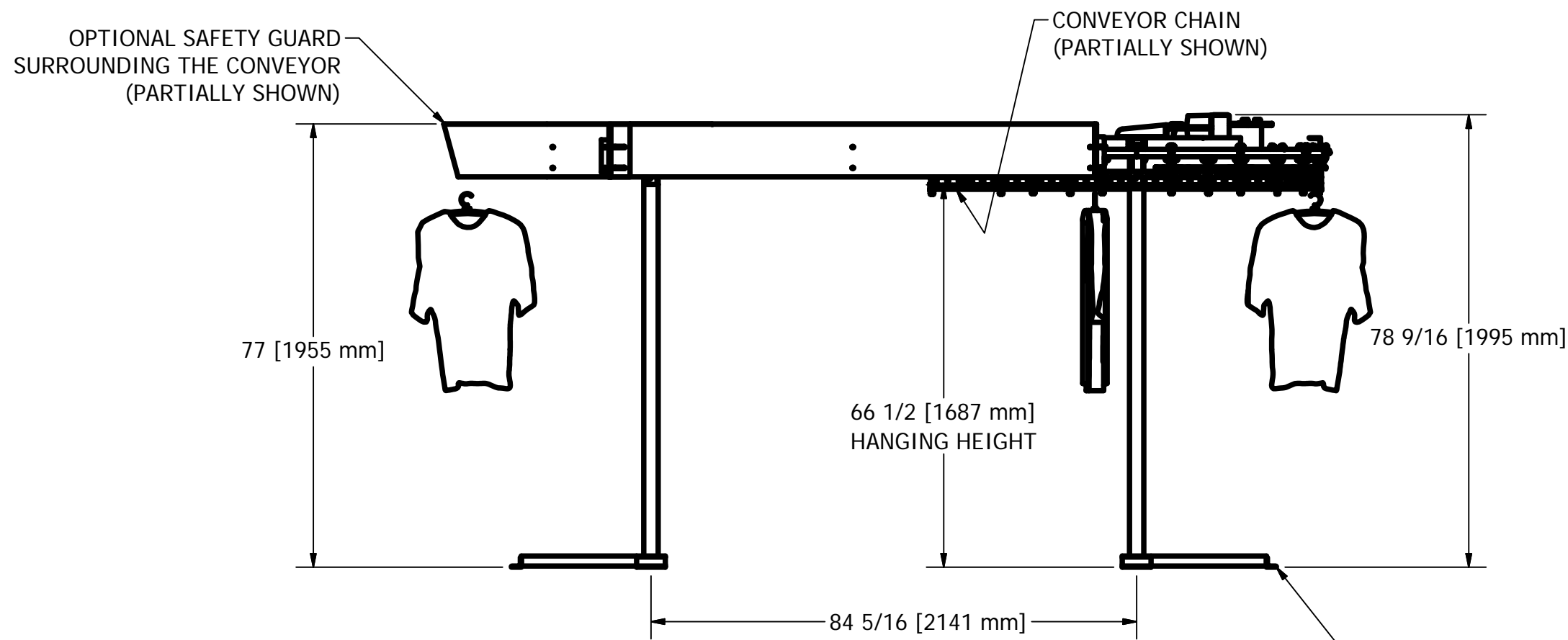
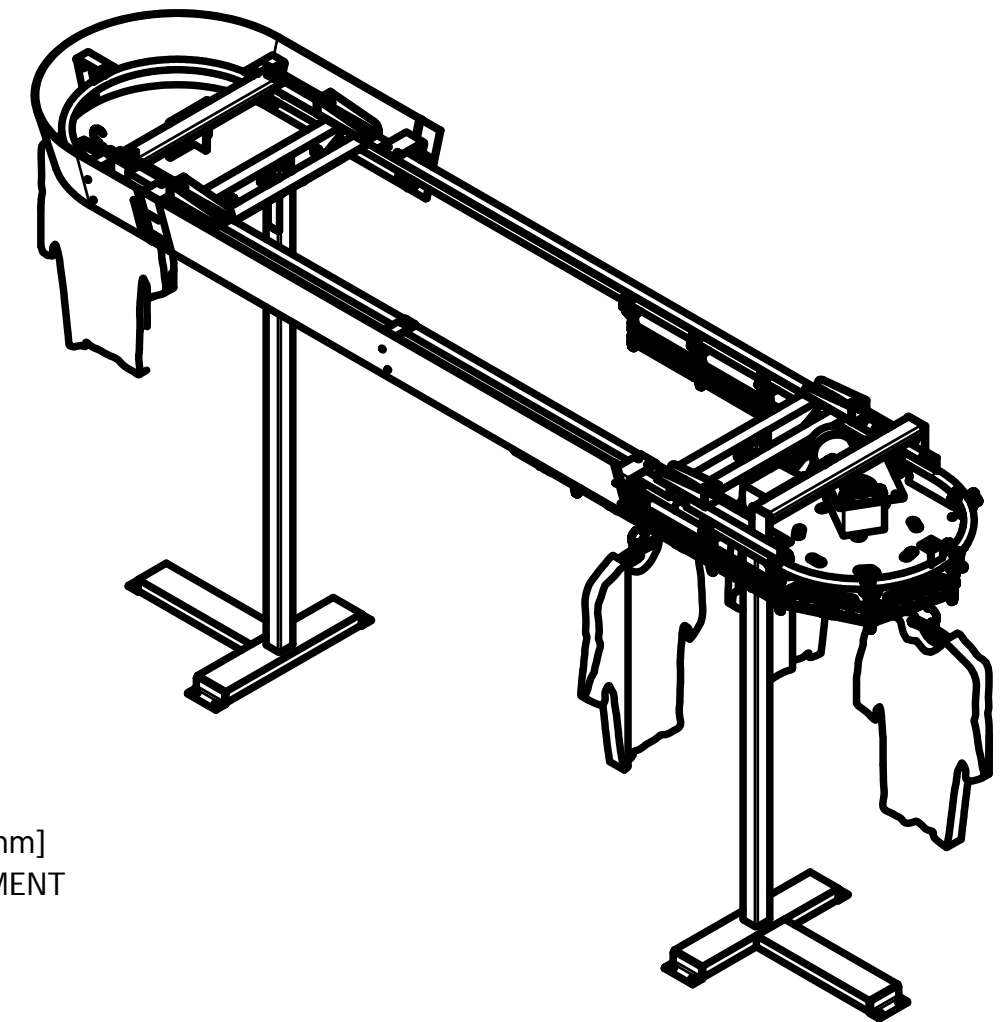
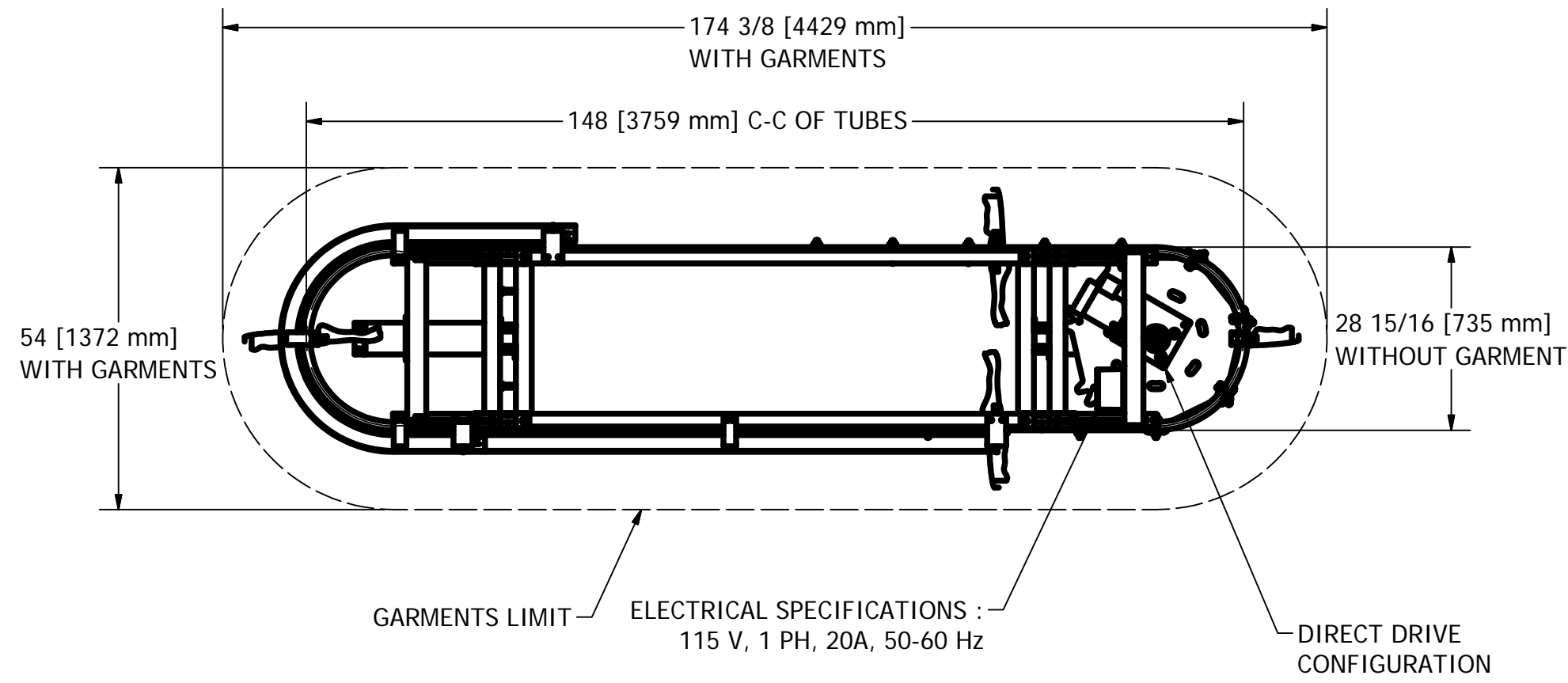

3/8" x 3-3/4" CONCRETE WEDGE ANCHORS REQUIRED (HILTI KB3 OR UCAN WED OR EQUIVALENT), 2-1/2" MINIMUM EMBEDMENT, TYP.

DESIGN F. ROULEAU	DATE 8/21/2008	 www.planiform.com
DRAWN F. ROULEAU	DATE 1/12/2010	
CHECKED	DATE	
GENERAL TOLERANCES X +/- .030 .XX +/- .010 .XXX +/- .005 FRACTION +/- 1/16		TITLE <b>GARMENT CONVEYOR</b>
SIZE C	DWG NO NPF-270	SCALE 1/2" = 1'-0"
		REV