

GENERAL NOTES :

CONVEYOR WEIGHT : 425 LB (without garment)
 APPROX. STORAGE CAPACITY : 696 GARMENTS
BRACING REQUIRED

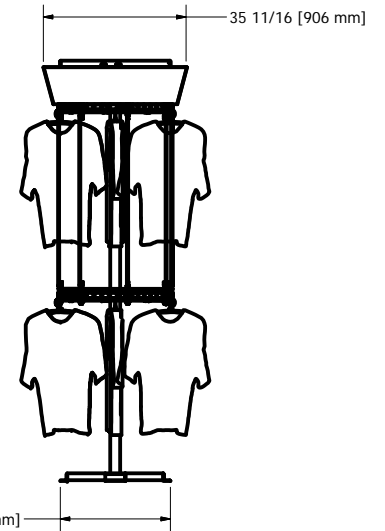
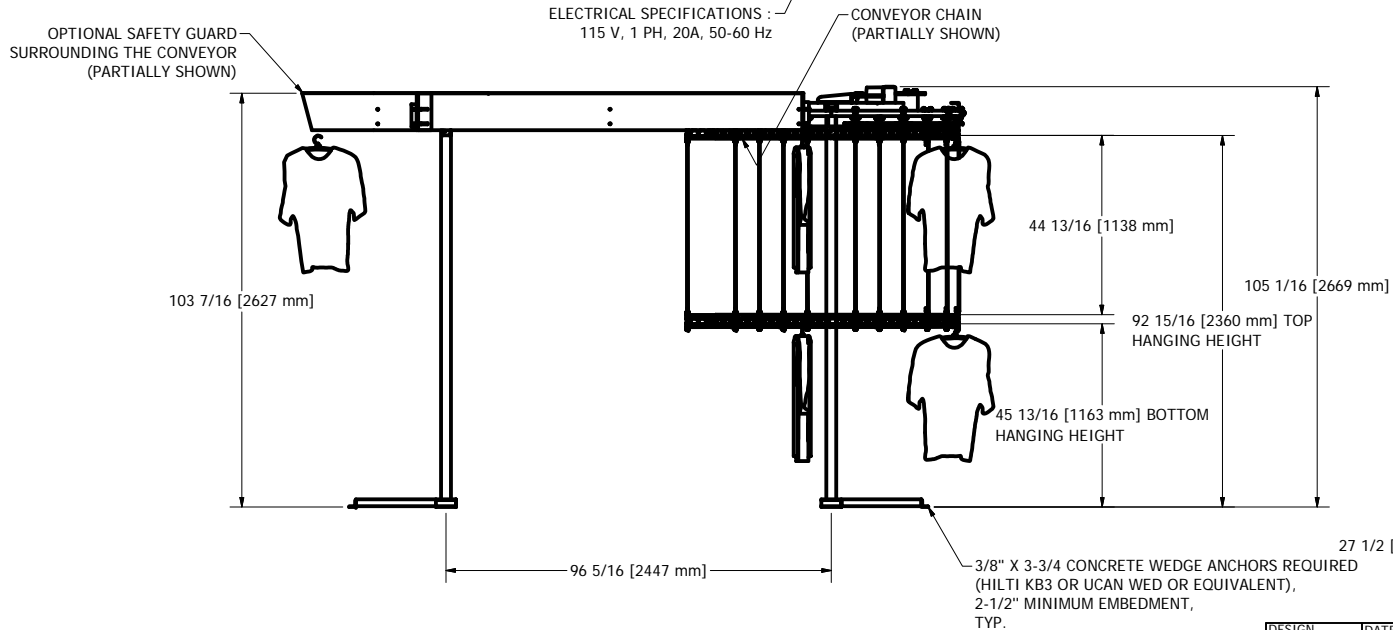
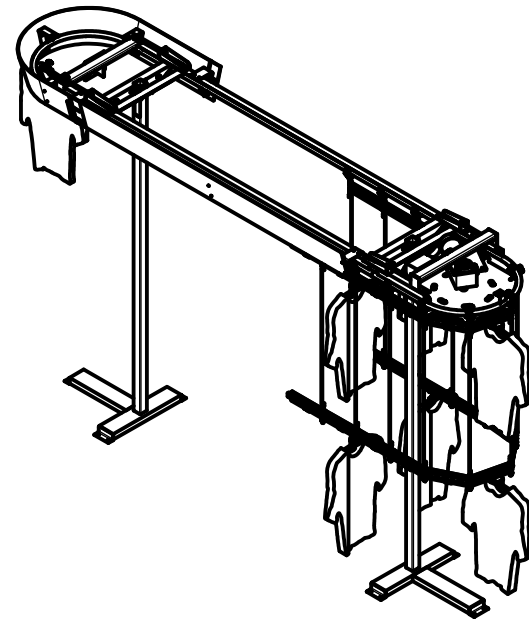
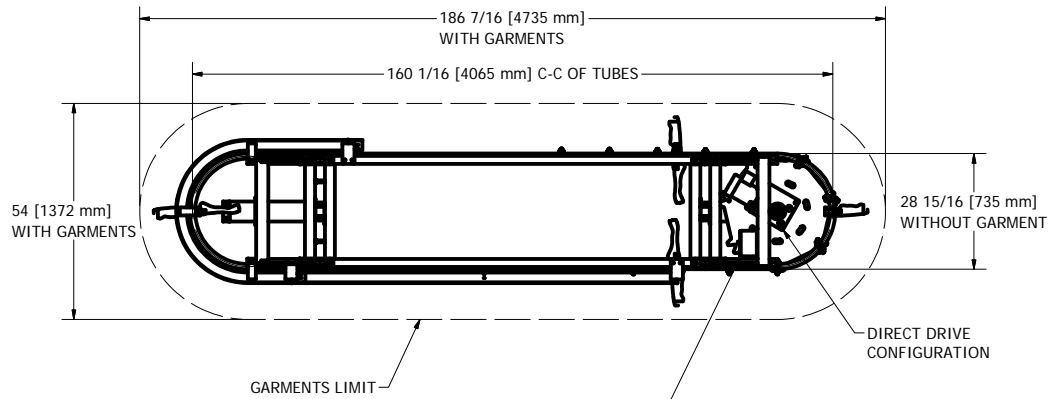

DESIGN	DATE
F. ROULEAU	8/21/2008
DRAWN	DATE
S. ROUS.-L.	1/15/2010
CHECKED	DATE
GENERAL TOLERANCES	
.X	+/- .030
.XX	+/- .010
.XXX	+/- .005
FRACTION	+/- 1/16

www.planiform.com		Planiform Conveyors	
TITLE			
GARMET CONVEYOR			
SIZE	DWG NO	SCALE	REV
C	NPF-290-DD	1/2" = 1'-0"	