

GENERAL NOTES :

CONVEYOR WEIGHT : 443 LB (without garment)
 APPROX. STORAGE CAPACITY : 744 GARMENTS
BRACING REQUIRED

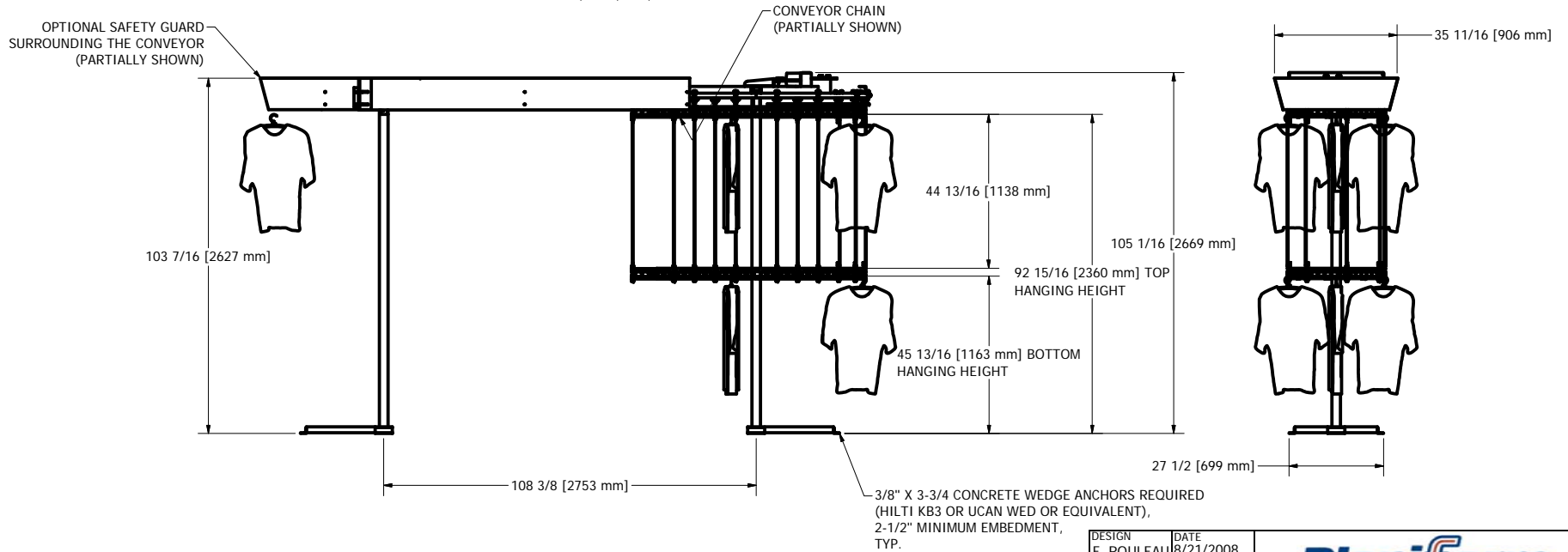
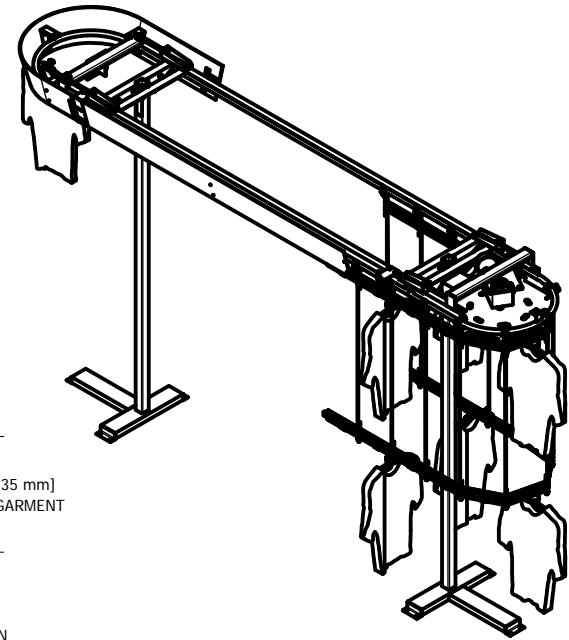
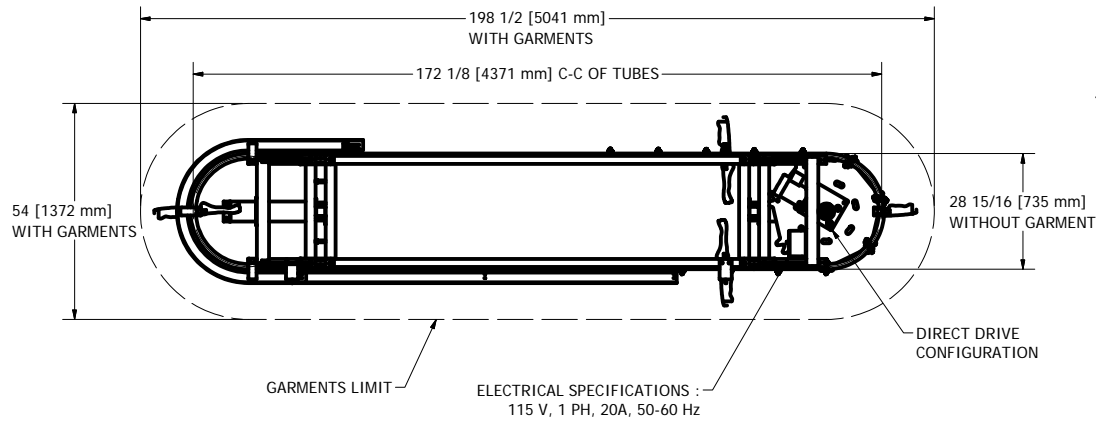

DESIGN F. ROULEAU	DATE 8/21/2008
DRAWN S. ROUS.-L.	DATE 1/15/2010
CHECKED	DATE
GENERAL TOLERANCES	
.X	+/- .030
.XX	+/- .010
.XXX	+/- .005
FRACTION	+/- 1/16

www.planiform.com			
TITLE GARMENT CONVEYOR			
SIZE C	DWG NO NPF-310-DD	SCALE 1/2" = 1'-0"	REV