

GENERAL NOTES :

CONVEYOR WEIGHT : 457 LB (without garment)
 APPROX. STORAGE CAPACITY : 792 GARMENTS
BRACING REQUIRED

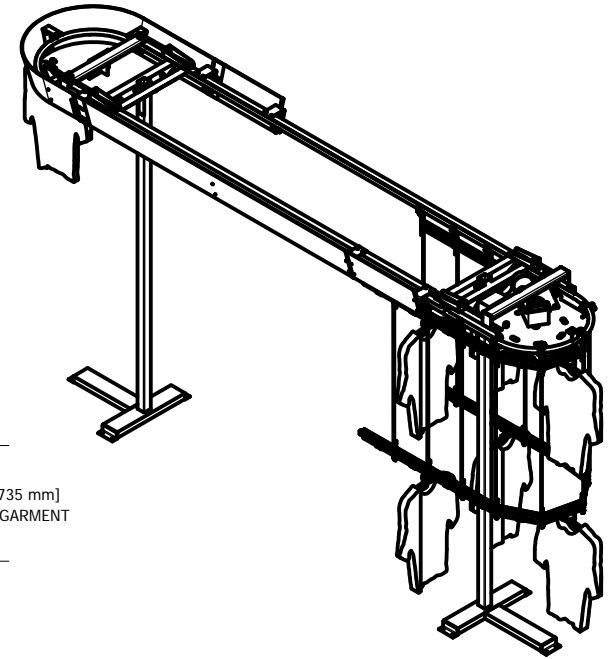

OPTIONAL SAFETY GUARD SURROUNDING THE CONVEYOR (PARTIALLY SHOWN)

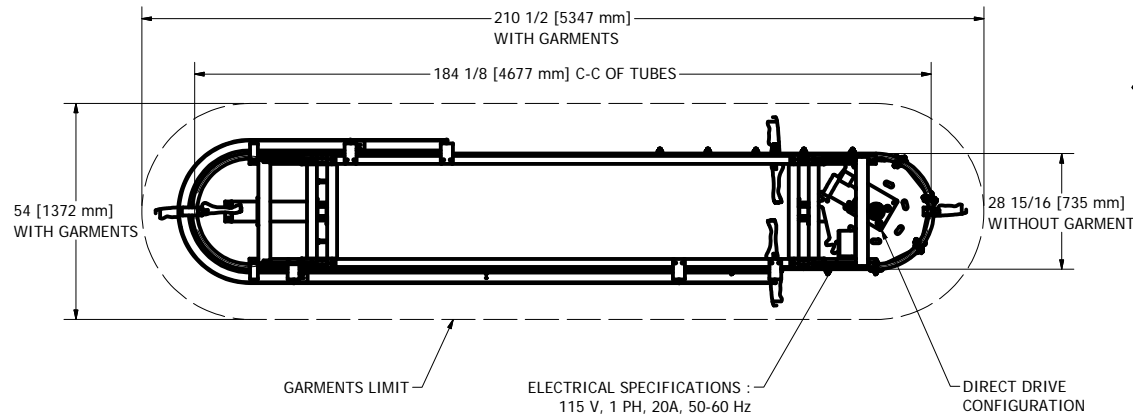
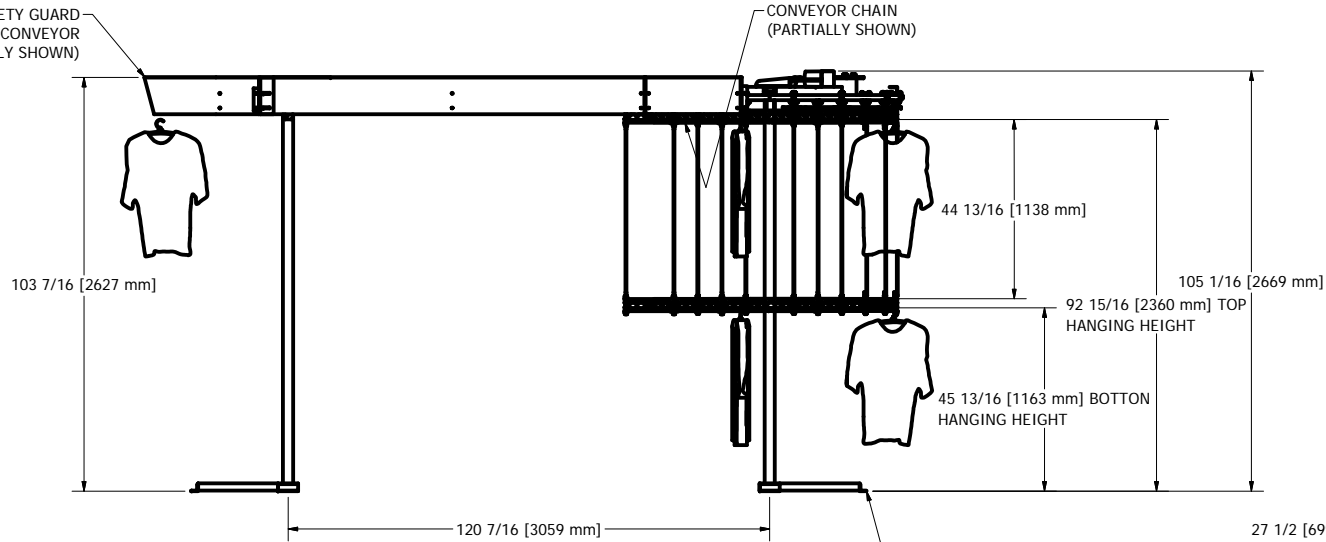

3/8" X 3-3/4 CONCRETE WEDGE ANCHORS REQUIRED (HILTI KB3 OR UCAN WED OR EQUIVALENT), 2-1/2" MINIMUM EMBEDMENT, TYP.

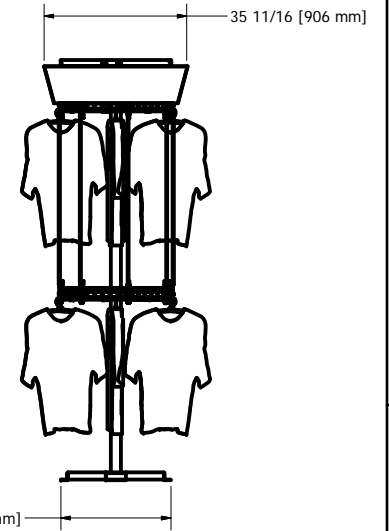

DESIGN F. ROULEAU	DATE 8/21/2008
DRAWN F. ROULEAU	DATE 1/12/2010
CHECKED	DATE
GENERAL TOLERANCES	
.X	+/- .030
.XX	+/- .010
.XXX	+/- .005
FRACTION	+/- 1/16

www.planiform.com			TITLE GARMENT CONVEYOR
SIZE C	DWG NO NPF-330-DD		