

GENERAL NOTES :

CONVEYOR WEIGHT : 537 LB (without garment)
 APPROX. STORAGE CAPACITY : 888 GARMENTS
BRACING REQUIRED

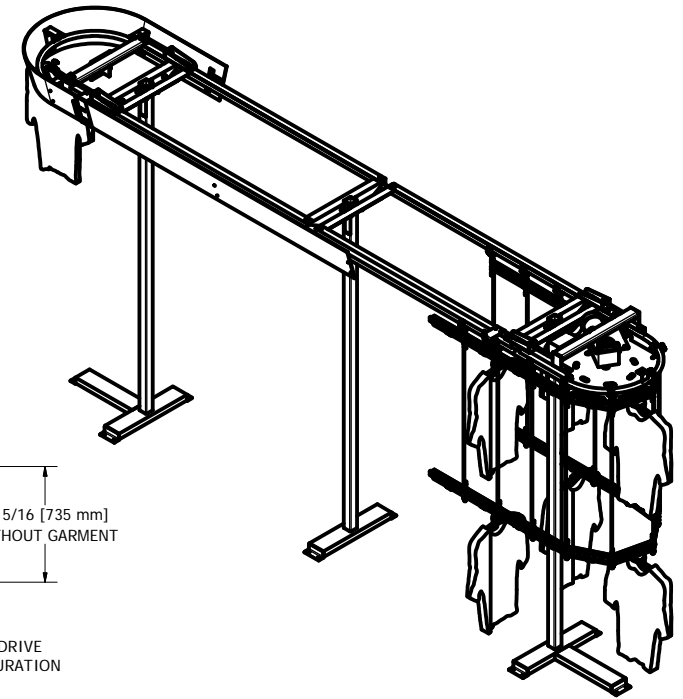

OPTIONAL SAFETY GUARD SURROUNDING THE CONVEYOR (PARTIALLY SHOWN)

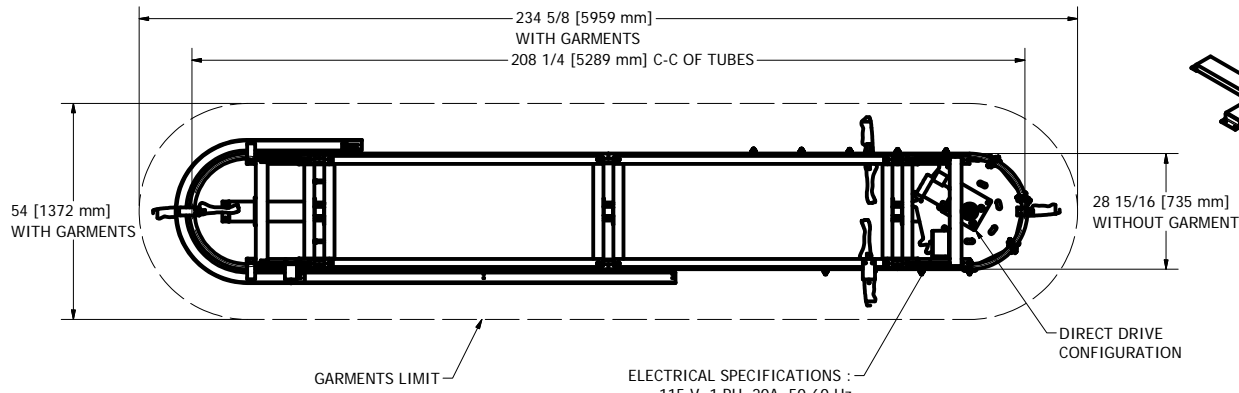
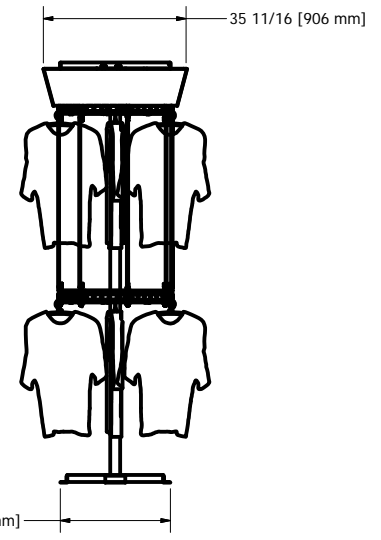
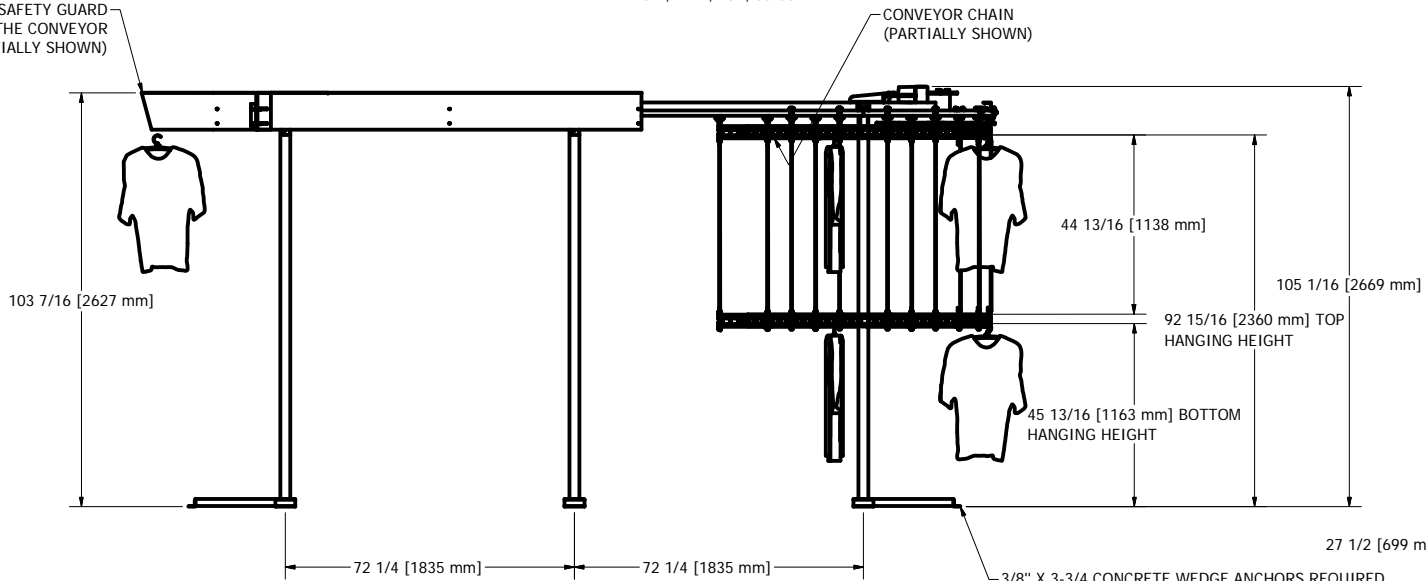

3/8" X 3-3/4" CONCRETE WEDGE ANCHORS REQUIRED (HILTI KB3 OR UCAN WED OR EQUIVALENT), 2-1/2" MINIMUM EMBEDMENT, TYP.

DESIGN F. ROULEAU	DATE 8/21/2008
DRAWN S. ROUS.-L.	DATE 1/15/2010
CHECKED	DATE
GENERAL TOLERANCES	
.X	+/- .030
.XX	+/- .010
.XXX	+/- .005
FRACTION	+/- 1/16

Planiform
 Conveyors
 www.planiform.com

TITLE
GARMENT CONVEYOR

SIZE C	DWG NO NPF-370-DD	SCALE 1/2" = 1'-0"	REV
-----------	----------------------	-----------------------	-----