

GENERAL NOTES :

CONVEYOR WEIGHT : 470 LB (without garment)
 APPROX. STORAGE CAPACITY : 468 GARMENTS

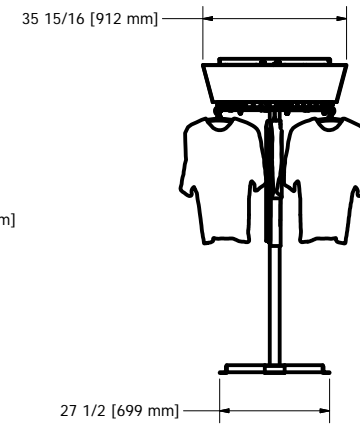
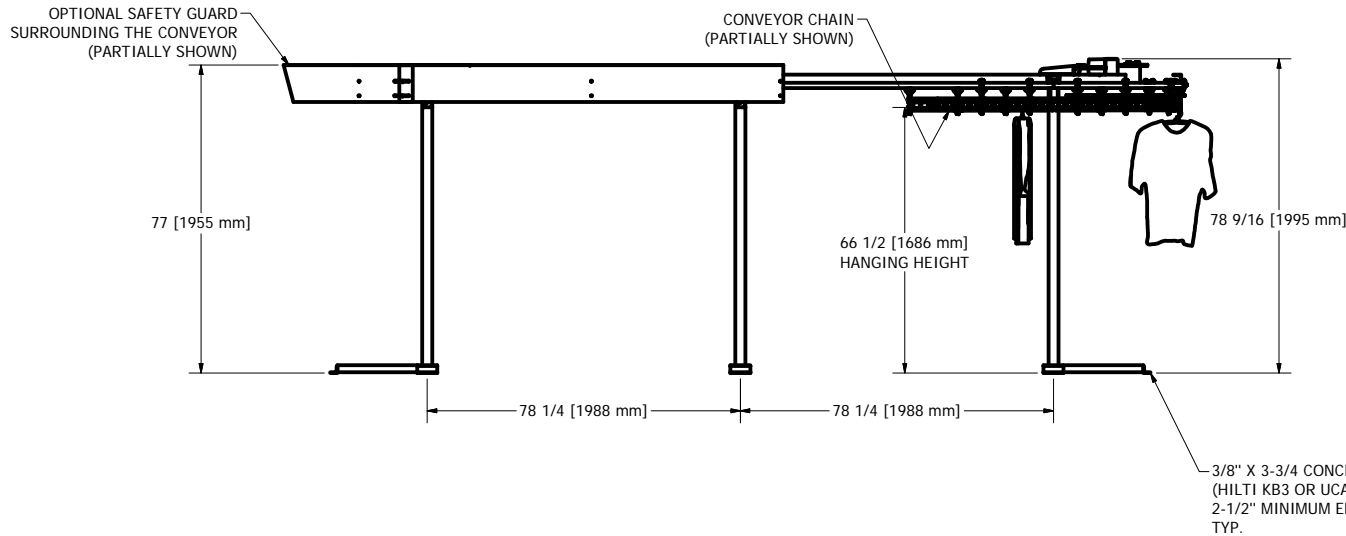
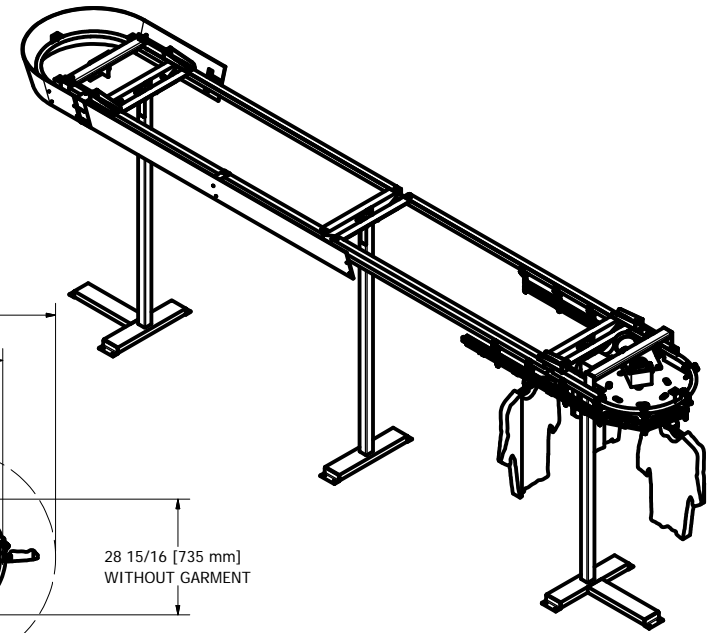
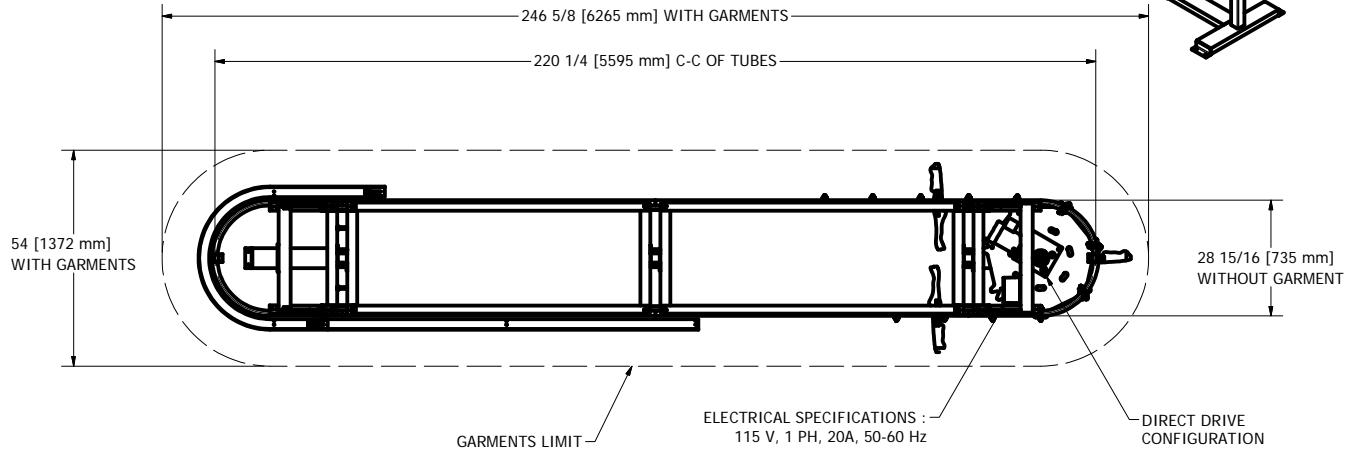

DESIGN	DATE
F. ROULEAU	2008-08-21
DRAWN	DATE
F. ROULEAU	2010-01-12
CHECKED	DATE
GENERAL TOLERANCES	
.X	+/- .030
.XX	+/- .010
.XXX	+/- .005
FRACTION	+/- 1/16

www.planiform.com	
TITLE	
GARMET CONVEYOR	
SIZE	DWG NO
C	NPF-390
SCALE	REV
1/2" = 1'-0"	