

GENERAL NOTES :

CONVEYOR WEIGHT : 593 LB (without garment)
 APPROX. STORAGE CAPACITY : 1080 GARMENTS
BRACING REQUIRED

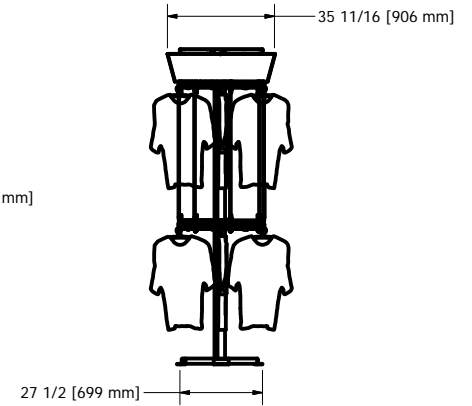
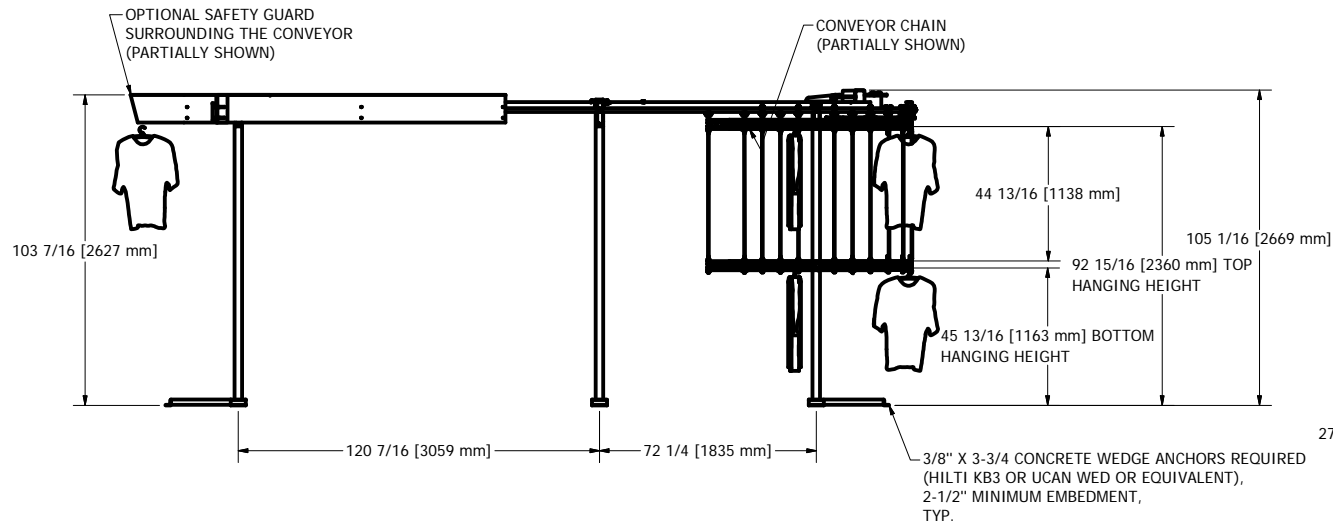
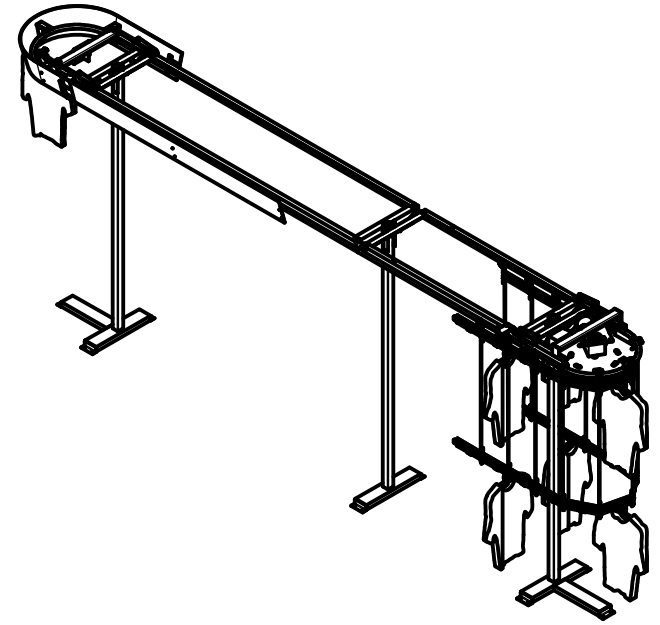
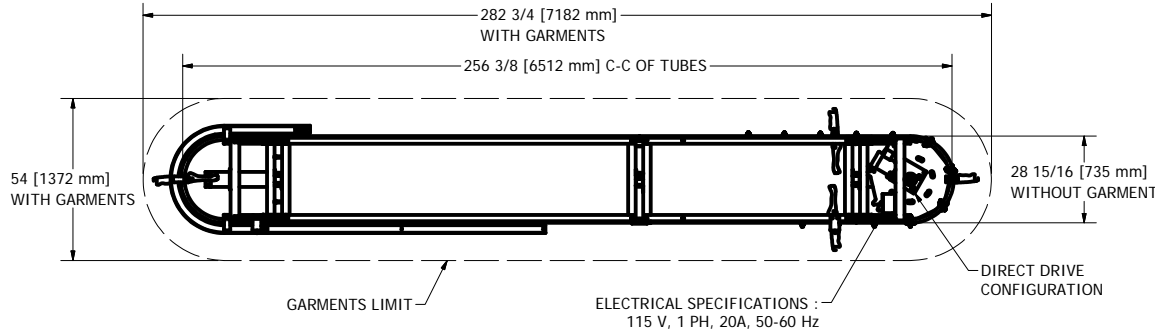

DESIGN F. ROULEAU	DATE 1/15/2010
DRAWN S. ROUS.-L.	DATE 1/18/2010
CHECKED	DATE
GENERAL TOLERANCES	
.X	+/- .030
.XX	+/- .010
.XXX	+/- .005
FRACTION	+/- 1/16

		www.planiform.com	
		TITLE GARMENT CONVEYOR	
SIZE C	DWG NO NPF-450-DD	SCALE 1/2" = 1'-0"	REV