

**GENERAL NOTES :**

CONVEYOR WEIGHT : 566 LB (without garment)  
 APPROX. STORAGE CAPACITY : 564 GARMENTS

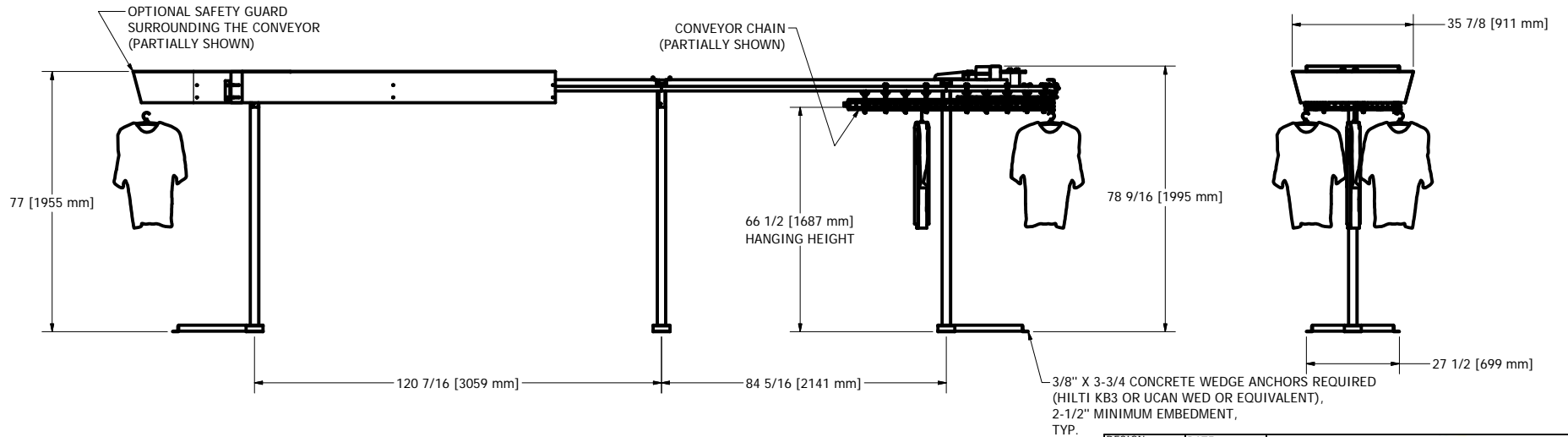
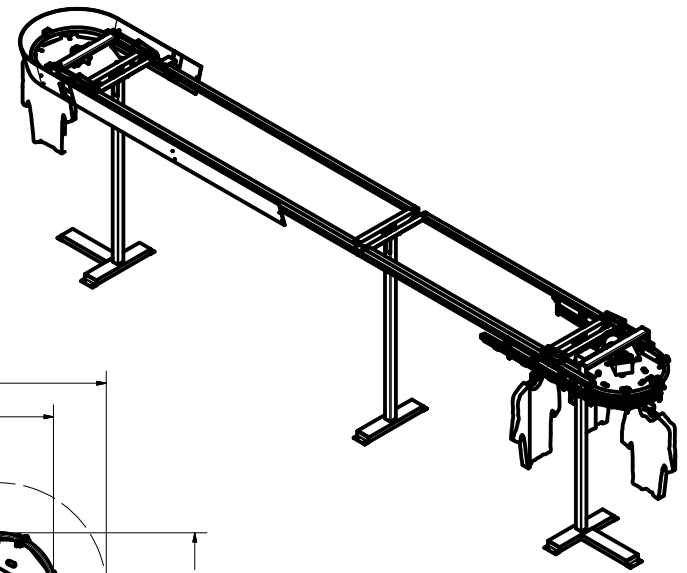
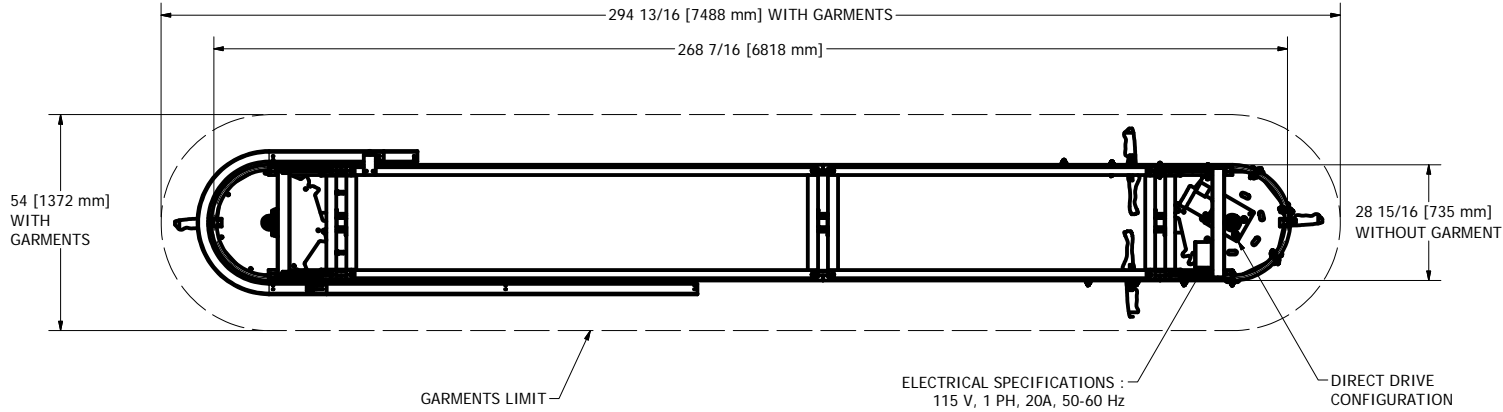

DESIGN	DATE
F. ROULEAU	2008-08-21
DRAWN	DATE
S. ROUS.-L.	2010-01-13
CHECKED	DATE
GENERAL TOLERANCES	
.X	+/- .030
.XX	+/- .010
.XXX	+/- .005
FRACTION	+/- 1/16

		TITLE	
		GARMET CONVEYOR	
SIZE	DWG NO	SCALE	REV
C	NPF-470	1/2" = 1'-0"	