

GENERAL NOTES :

CONVEYOR WEIGHT : 579 LB (without garment)
 APPROX. STORAGE CAPACITY : 588 GARMENTS

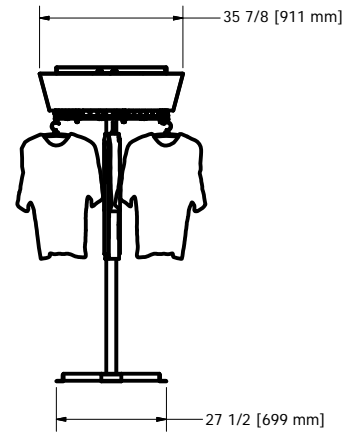
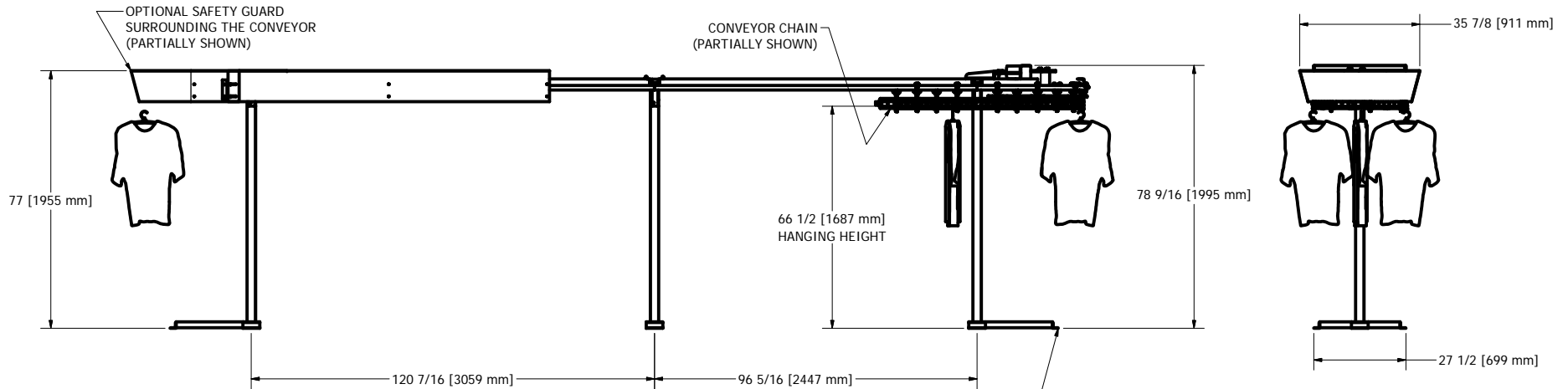
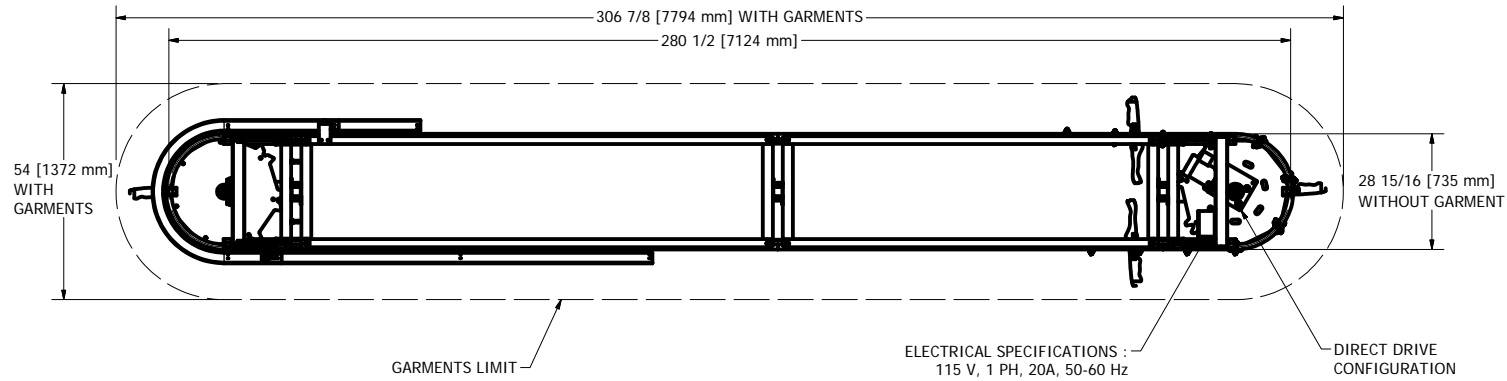
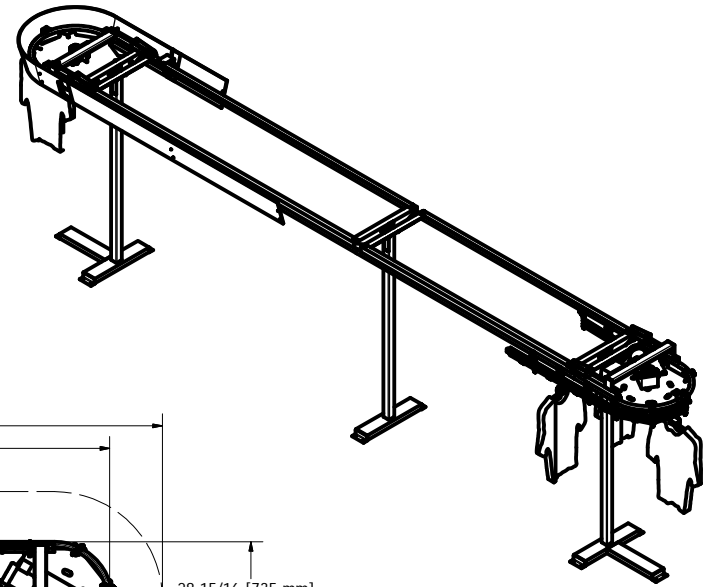

3/8" X 3-3/4 CONCRETE WEDGE ANCHORS REQUIRED (HILTI KB3 OR UCAN WED OR EQUIVALENT), 2-1/2" MINIMUM EMBEDMENT, TYP.

| | |
|----------------------|-------------------|
| DESIGN F. ROULEAU | DATE 8/21/2008 |
| DRAWN S. ROUS.-L. | DATE 1/13/2010 |
| CHECKED | DATE |
| GENERAL TOLERANCES | |
| .X | +/- .030 |
| .XX | +/- .010 |
| .XXX | +/- .005 |
| FRACTION | +/- 1/16 |

Planiform
Conveyors

www.planiform.com

TITLE
GARMENT CONVEYOR

| | | | |
|-----------|-------------------|-----------------------|-----|
| SIZE C | DWG NO NPF-490 | SCALE 1/2" = 1'-0" | REV |
|-----------|-------------------|-----------------------|-----|