

GENERAL NOTES :

CONVEYOR WEIGHT : 637 LB (without garment)
 APPROX. STORAGE CAPACITY : 1224 GARMENTS
BRACING REQUIRED

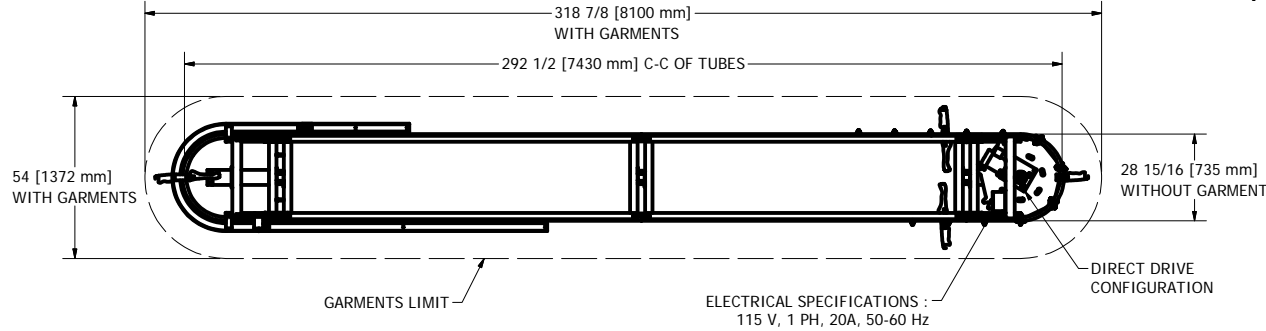

ELECTRICAL SPECIFICATIONS :
 115 V, 1 PH, 20A, 50-60 Hz

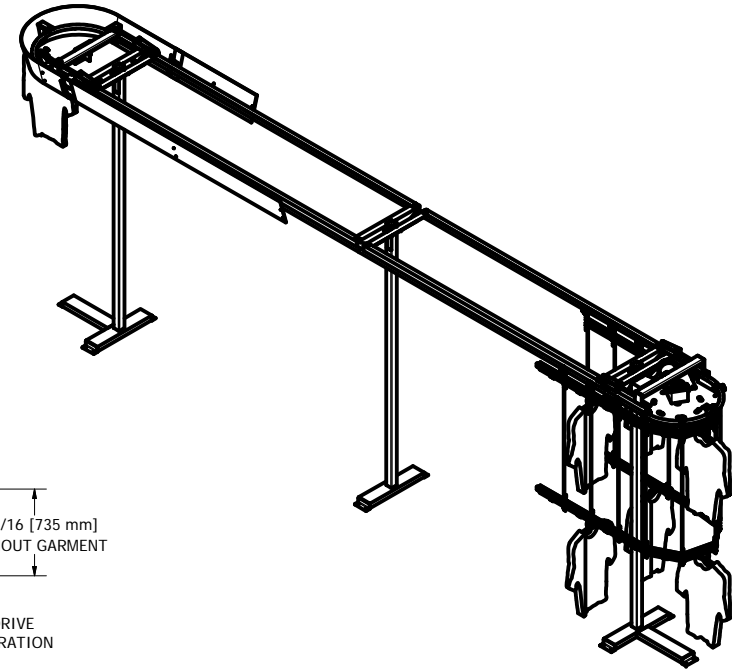
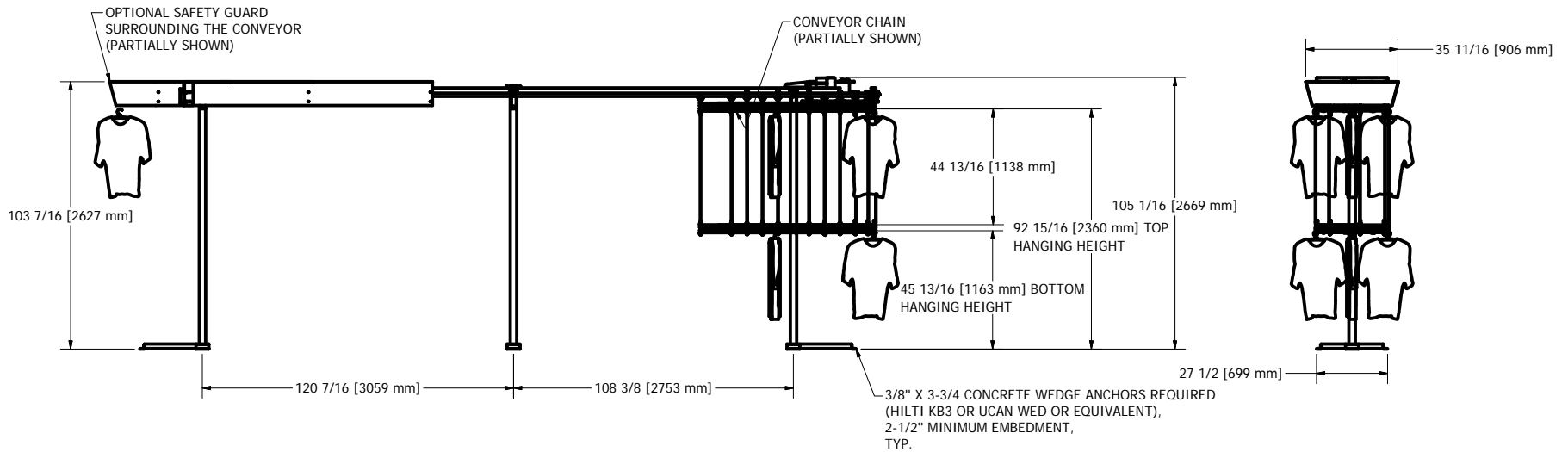

DESIGN F. ROULEAU	DATE 1/27/2010
DRAWN S. ROUS.-L.	DATE 1/27/2010
CHECKED	DATE
GENERAL TOLERANCES	
.X	+/- .030
.XX	+/- .010
.XXX	+/- .005
FRACTION	+/- 1/16

		www.planiform.com	
		TITLE GARMENT CONVEYOR	
SIZE C	DWG NO NPF-510-DD	SCALE 3/8" = 1'-0"	REV