

GENERAL NOTES :

CONVEYOR WEIGHT : 849 LB (without garment)
 APPROX. STORAGE CAPACITY : 1752 GARMENTS
BRACING REQUIRED

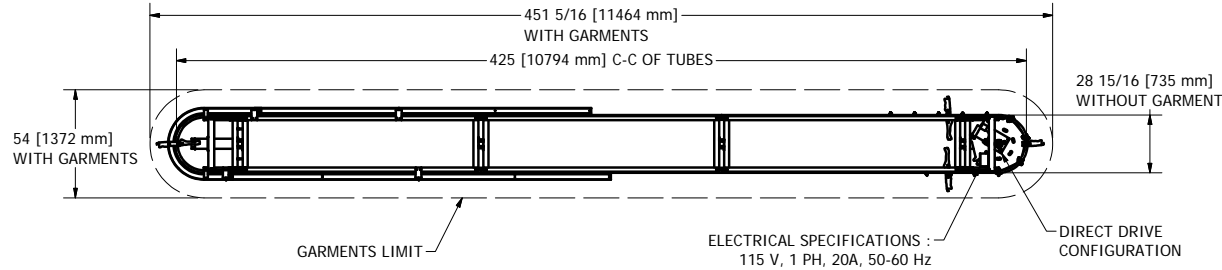

ELECTRICAL SPECIFICATIONS :
 115 V, 1 PH, 20A, 50-60 Hz

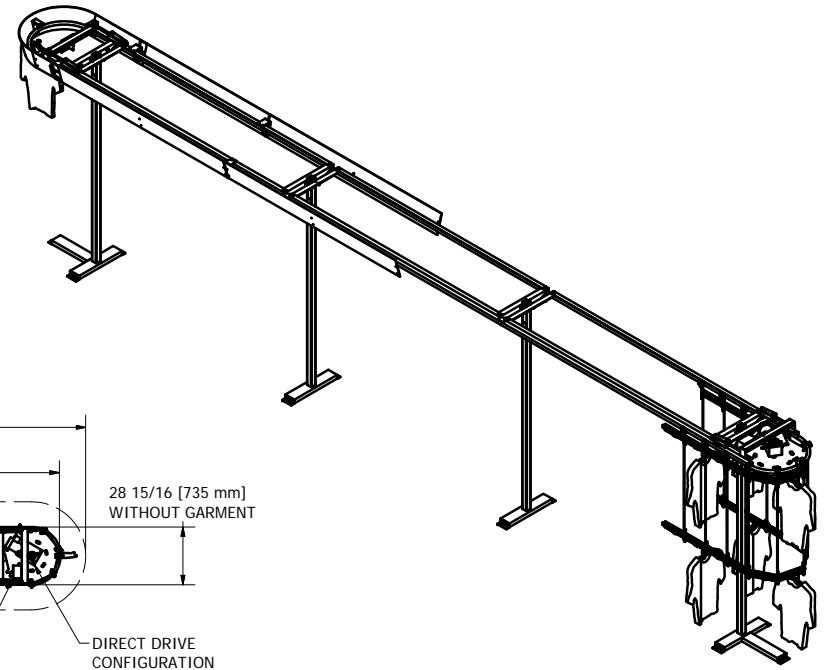
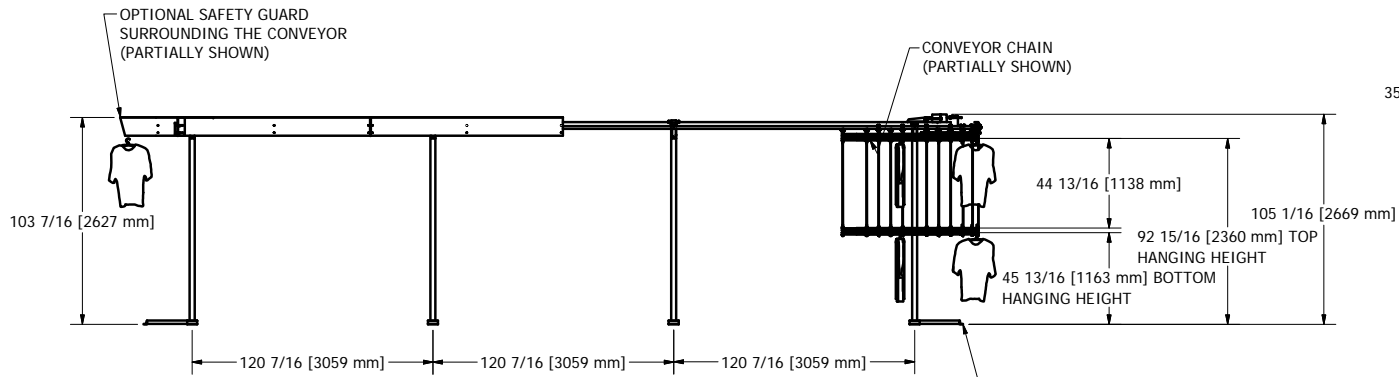

3/8" X 3-3/4 CONCRETE WEDGE ANCHORS REQUIRED
 (HILTI KB3 OR UCAN WED OR EQUIVALENT),
 2-1/2" MINIMUM EMBEDMENT,
 TYP.

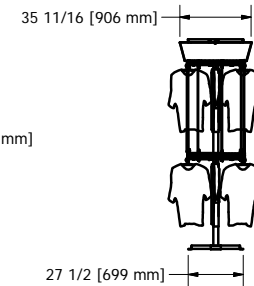

DESIGN F. ROULEAU	DATE 1/27/2010
DRAWN S. ROUS.-L.	DATE 1/29/2010
CHECKED	DATE
GENERAL TOLERANCES	
.X	+/- .030
.XX	+/- .010
.XXX	+/- .005
FRACTION	+/- 1/16

www.planiform.com		Planiform Conveyors	
TITLE GARMENT CONVEYOR			
SIZE C	DWG NO NPF-730-DD	SCALE 1/4" = 1'-0"	REV