

**GENERAL NOTES :**

CONVEYOR WEIGHT : 947 LB (without garment)  
 APPROX. STORAGE CAPACITY : 1896 GARMENTS  
**BRACING REQUIRED**

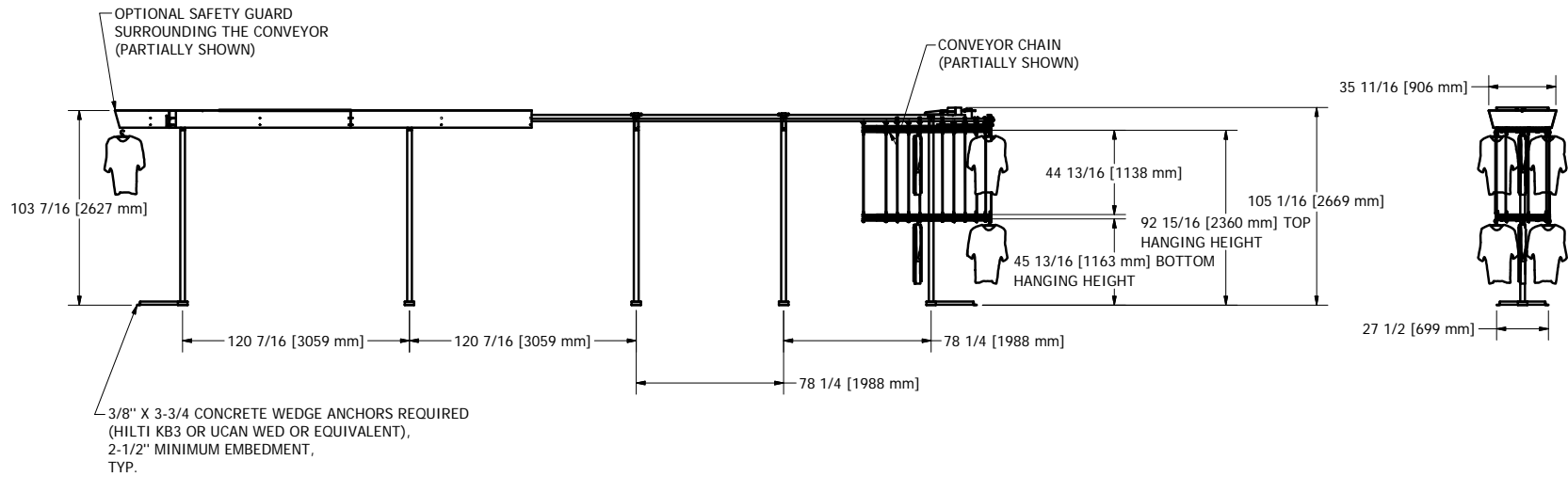
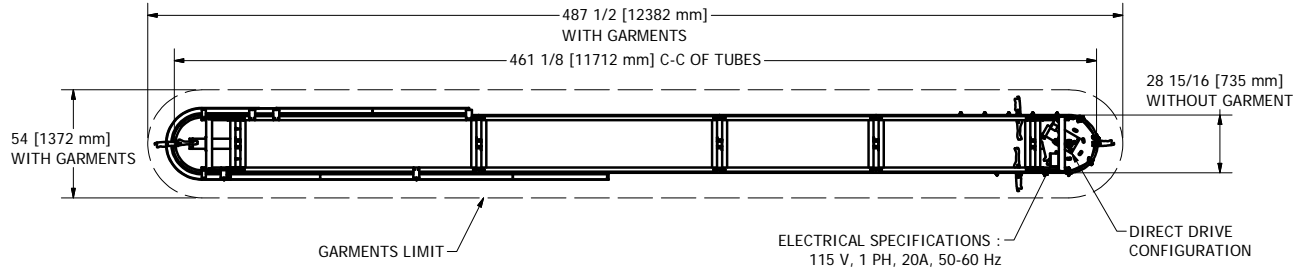
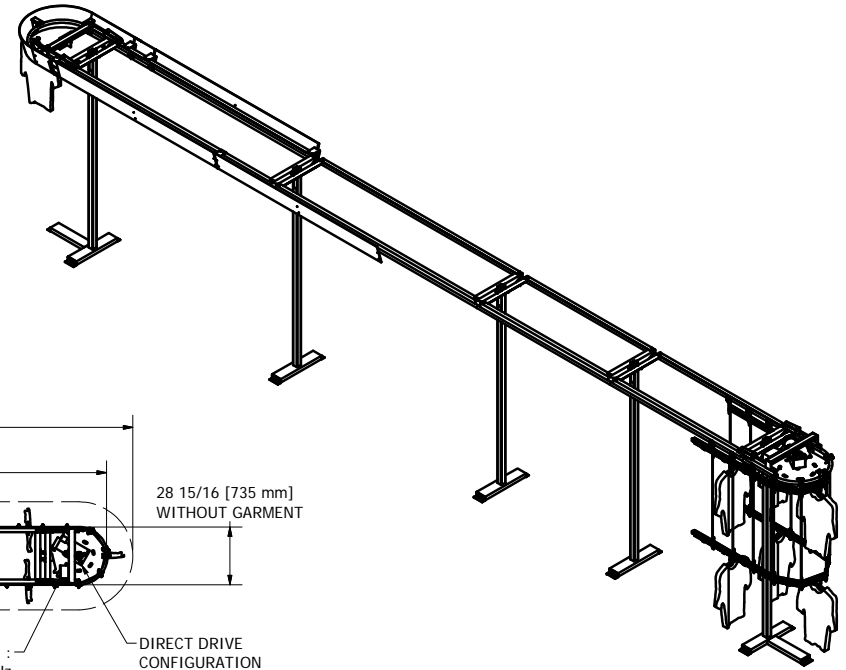

DESIGN F. ROULEAU	DATE 1/27/2010	 www.planiform.com		
DRAWN S. ROUS.-L.	DATE 1/29/2010			
CHECKED	DATE	TITLE <b>GARMENT CONVEYOR</b>		
GENERAL TOLERANCES .X +/- .030 .XX +/- .010 .XXX +/- .005 FRACTION +/- 1/16		SIZE DWG NO C NPF-790-DD	SCALE 1/4" = 1'-0"	REV