

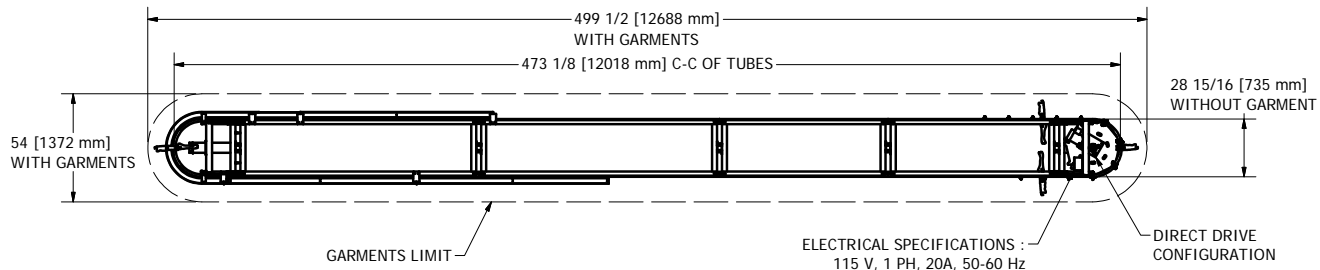

**GENERAL NOTES :**

CONVEYOR WEIGHT : 961 LB (without garment)  
 APPROX. STORAGE CAPACITY : 1944 GARMENTS  
**BRACING REQUIRED**

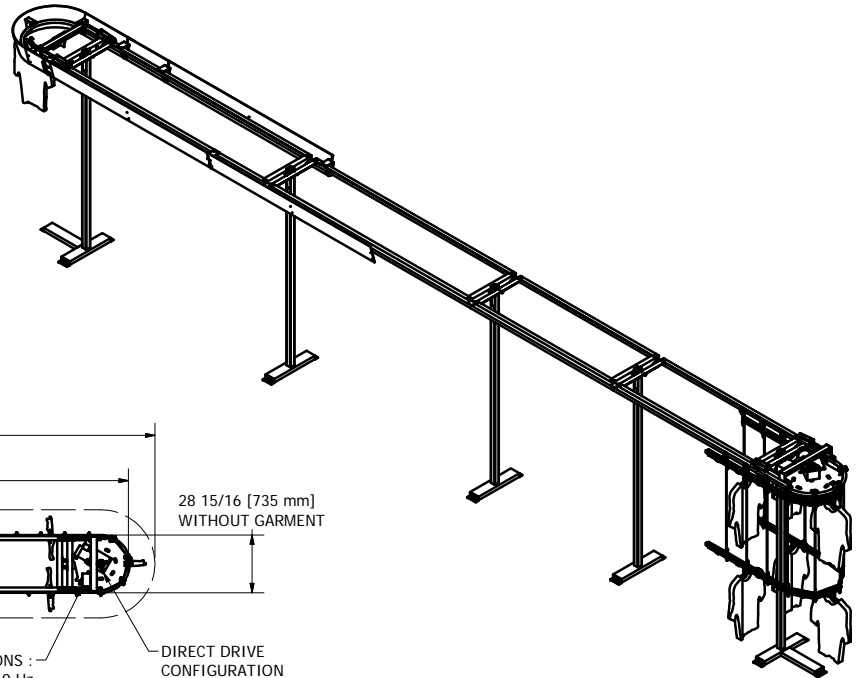
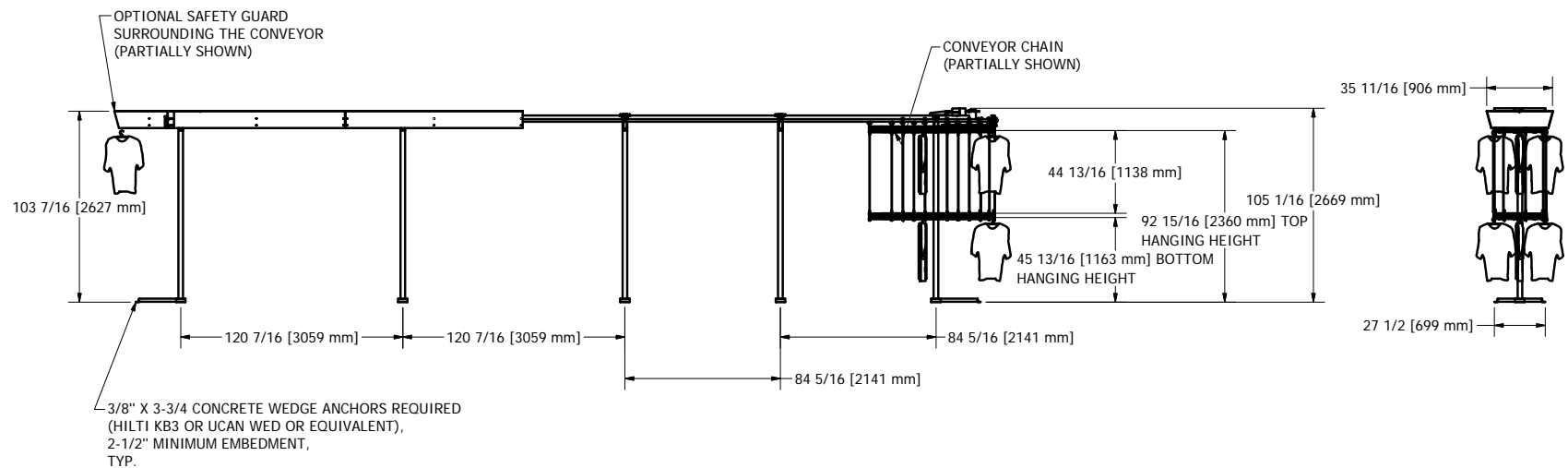

ELECTRICAL SPECIFICATIONS :  
 115 V, 1 PH, 20A, 50-60 Hz



DESIGN F. ROULEAU	DATE 1/27/2010			
DRAWN S. ROUS.-L.	DATE 1/29/2010			
CHECKED	DATE			
GENERAL TOLERANCES .X +/- .030 .XX +/- .010 .XXX +/- .005 FRACTION +/- 1/16		TITLE <b>GARMENT CONVEYOR</b>	SCALE 1/4" = 1'-0"	REV
SIZE DWG NO C NPF-810-DD		www.planiform.com		