

GENERAL NOTES :

CONVEYOR WEIGHT : 846 LB (without garment)
 APPROX. STORAGE CAPACITY : 972 GARMENTS

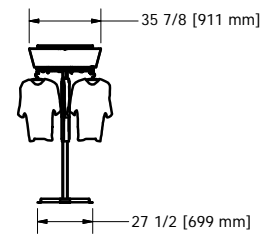
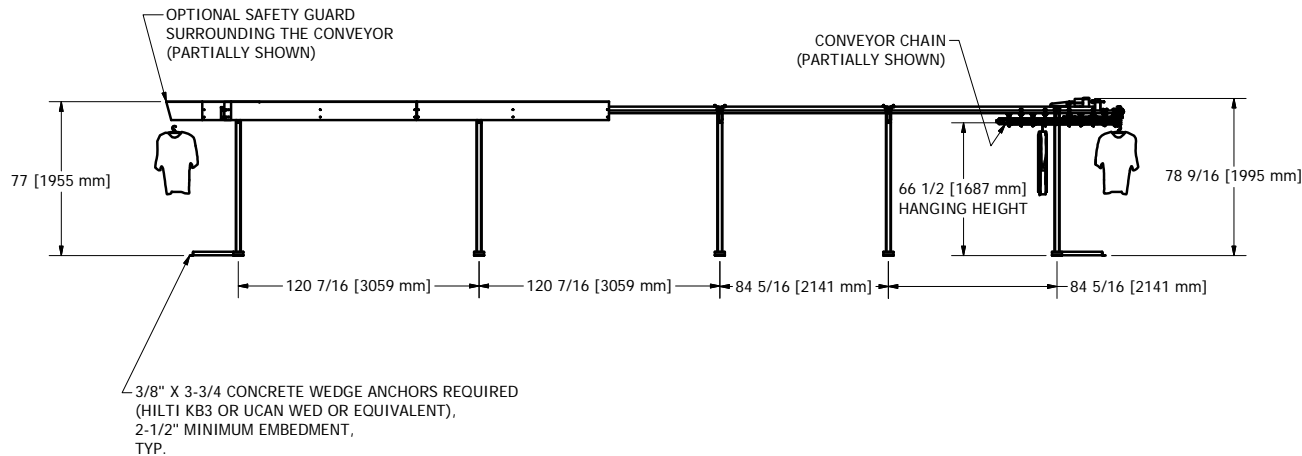
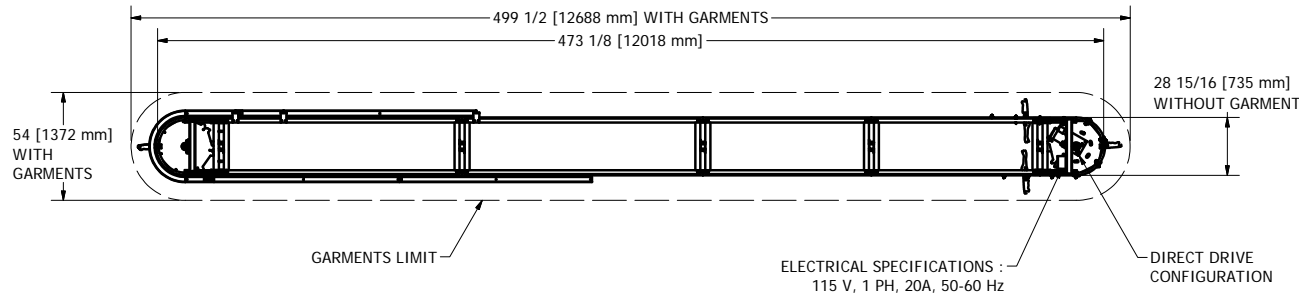
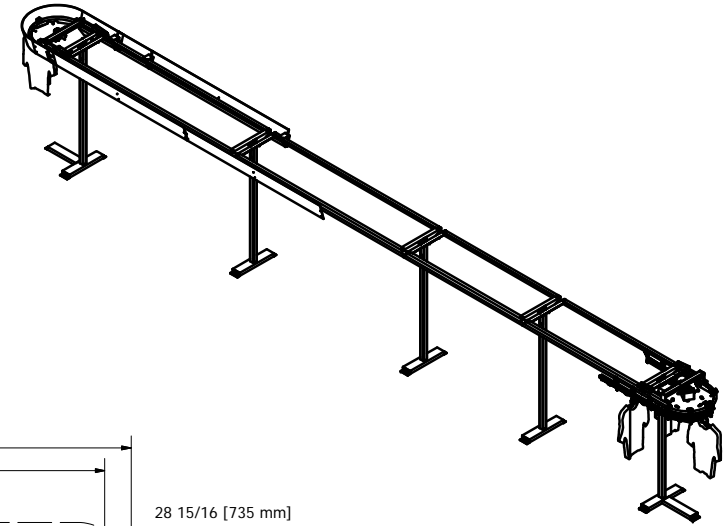

DESIGN F. ROULEAU	DATE 1/18/2010	 www.planiform.com TITLE GARMENT CONVEYOR			
DRAWN S. ROUS.-L.	DATE 1/18/2010				
CHECKED	DATE				
GENERAL TOLERANCES		SIZE C	DWG NO NPF-810	SCALE 1/4" = 1'-0"	REV
.X	+/- .030				
.XX	+/- .010				
.XXX	+/- .005				
FRACTION	+/- 1/16				