

GENERAL NOTES :

CONVEYOR WEIGHT : 975 LB (without garment)
 APPROX. STORAGE CAPACITY : 1992 GARMENTS
BRACING REQUIRED

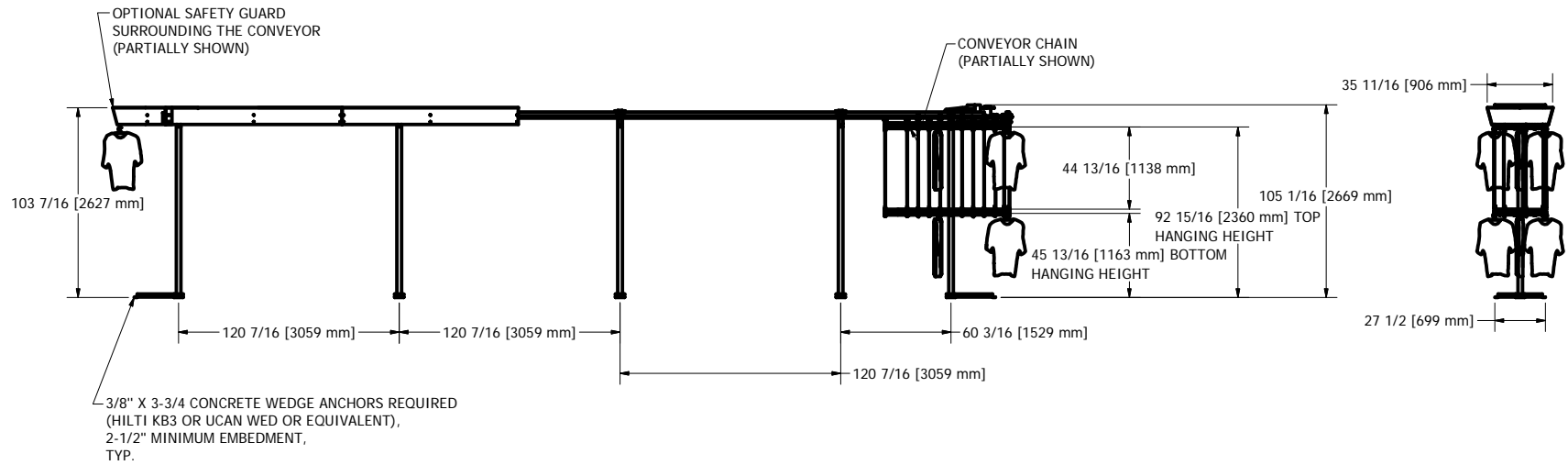
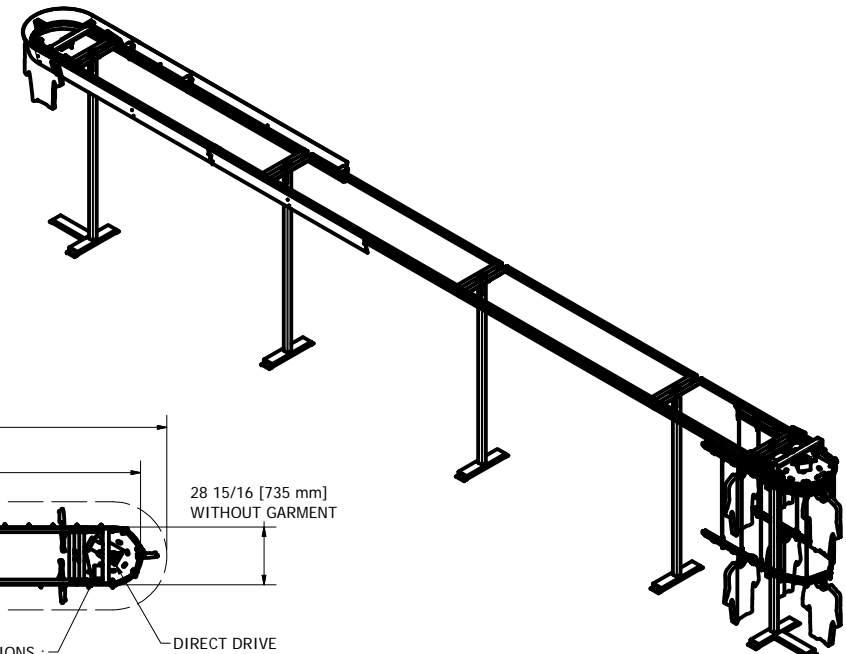
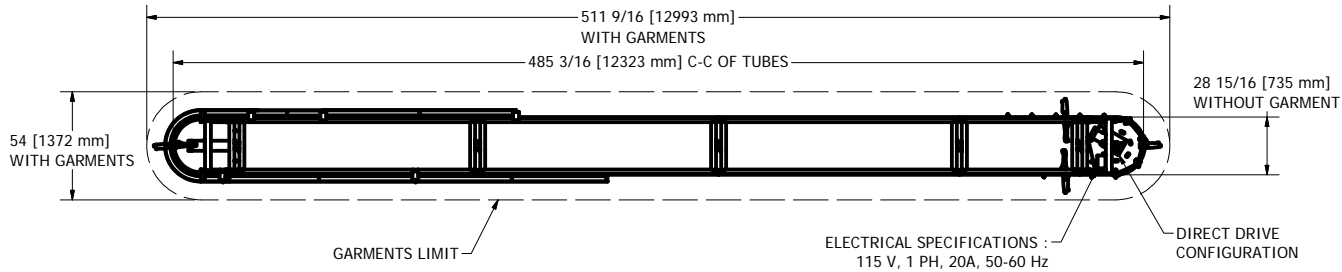

DESIGN F. ROULEAU	DATE 1/27/2010	 www.planiform.com	TITLE GARMENT CONVEYOR	SIZE C	DWG NO NPF-830-DD	SCALE 1/4" = 1'-0"	REV
DRAWN S. ROUS.-L.	DATE 1/29/2010						
CHECKED	DATE						
GENERAL TOLERANCES							
.X	+/- .030						
.XX	+/- .010						
.XXX	+/- .005						
FRACTION	+/- 1/16						