

GENERAL NOTES :

CONVEYOR WEIGHT : 1143 LB (without garment)
 APPROX. STORAGE CAPACITY : 2376 GARMENTS
BRACING REQUIRED

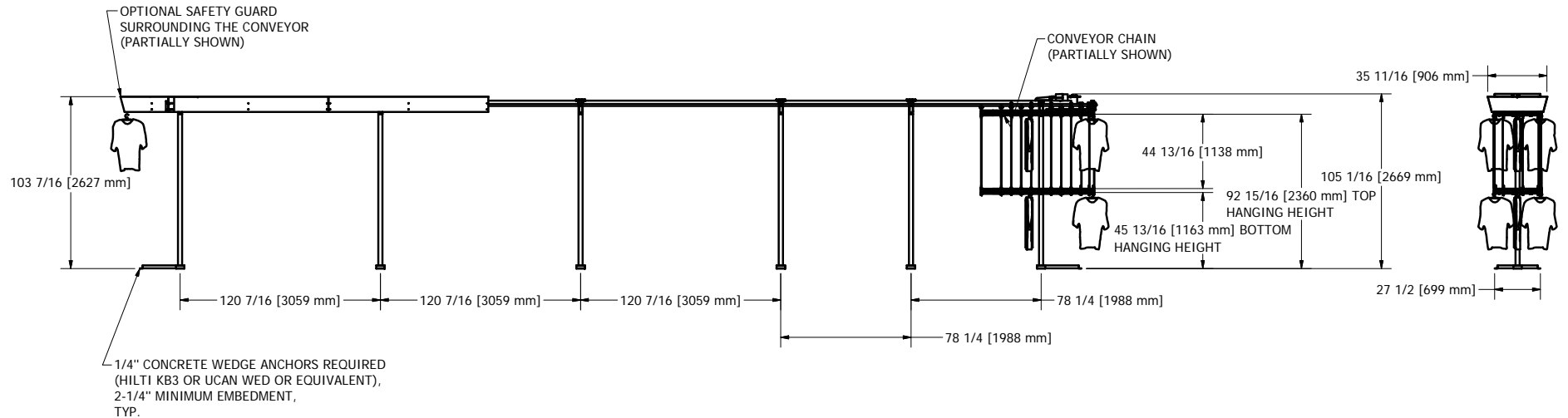
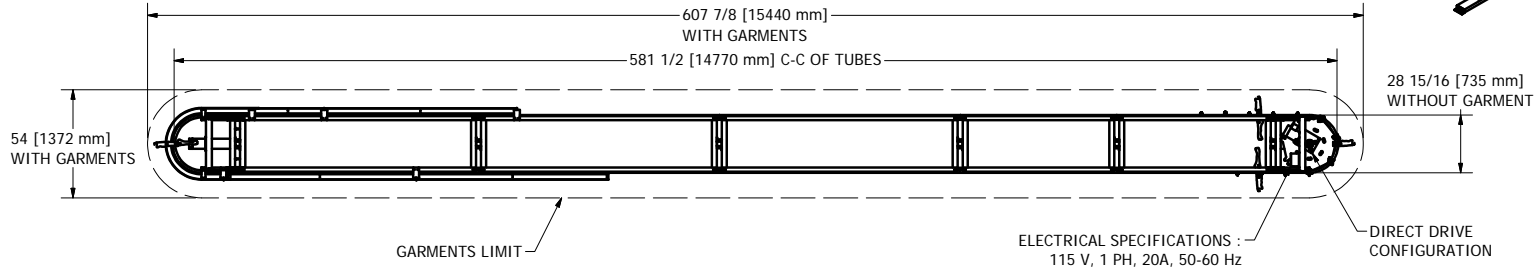
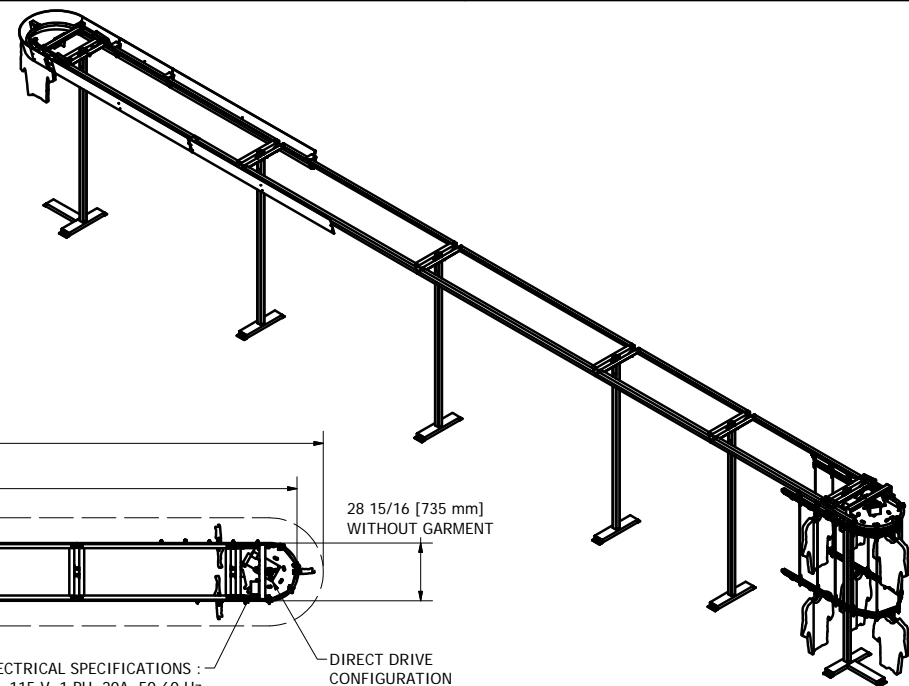

DESIGN F. ROULEAU	DATE 1/27/2010	 www.planiform.com TITLE GARMENT CONVEYOR		
DRAWN S. ROUS.-L.	DATE 1/29/2010			
CHECKED	DATE			
GENERAL TOLERANCES		SIZE DWG NO	SCALE	REV
.X	+/- .030	C	1/4" = 1'-0"	
.XX	+/- .010	NPF-990-DD		
.XXX	+/- .005			
FRACTION	+/- 1/16			